

**Features**

The 4452 is a natural gas burner specifically designed to provide a low emission flame in low temperature furnaces and ovens. Direct fired aluminum homogenizers and other low temperature heat treat furnaces are ideal applications. The burner is designed for vertical firing but can be fired horizontally without modification in applications below 1200°F.

The burner has an alloy flame protection tube which helps control emissions. Heat release to the tube is very even, which minimizes hot spots and increases tube life.

The burner is ignited with a simple low cost direct spark igniter (comes with burner) and has a wide lighting window. Flame supervision can be provided with either a UV scanner or flame rod (sold separately). A 3/4" observation port is also provided as well as locations for 1/8" air and gas pressure taps.

**NOx and CO Suppression Technologies**

The 4452 utilizes a number of NOx and CO suppression techniques. Air staging and self-recirculated FGR (flue gas recirculation) are used to reduce NOx. NOx emissions are reduced by nearly half compared to conventional burners. Air staging works by adding the air to the fuel in controlled

**The 4452 Advantage:**

- Low NOx and CO emissions for low temperature furnaces and ovens without externally supplied FGR
- Wide turndown range / wide stability range
- All metal flame protection tube, no refractory required
- Direct spark ignition
- U.V. or flame rod supervision
- Sturdy industrial construction with stainless steel flame stabilizer
- NPT (USA) or metric fittings available
- For applications up to 1400°F if vertically fired or 1200°F if horizontally fired

"stages" which delays combustion. The addition of FGR lowers the peak flame temperature by adding thermal ballast and by reducing the concentration of oxygen in the flame. Conventional FGR systems require additional exhaust piping but the 4452 is able to self-entrain FGR directly from the furnace or oven atmosphere.

CO is controlled with the help of the flame protection tube which shields the flame from the quenching effects of relatively cool recirculating flue gas.

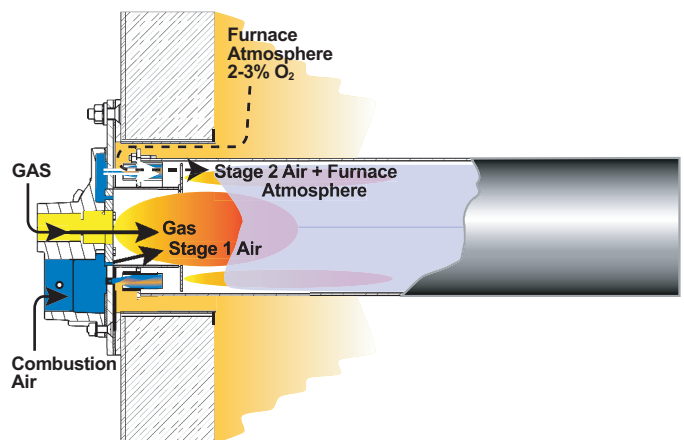

**cfh Air Capacity in Cold Furnace with Air Pressure across the burner**

| Burner Size | .5 osi | 1 osi | 4 osi  | 9 osi  | 16 osi | 20 osi |
|-------------|--------|-------|--------|--------|--------|--------|
| 4452-6-A    | 1,910  | 2,700 | 5,560  | 8,310  | 11,110 | 12,420 |
| 4452-6-B    | 2,690  | 3,800 | 7,700  | 11,530 | 15,630 | 17,430 |
| 4452-7      | 4,720  | 6,680 | 13,050 | 19,750 | 26,180 | 29,580 |
| 4452-8-A    | 6,320  | 8,940 | 18,020 | 26,930 | 36,360 | 40,710 |

**Flame Dimensions**  
at 16 osi (10% XSAir)  
beyond flame protection tube

| Length | Diameter |
|--------|----------|
| 2'     | 1'       |
| 2'     | 1'       |
| 2'     | 1'       |
| 3'     | 1 1/2'   |

## Construction

The burner body is constructed of sturdy cast iron. Mounting plates are steel, and the flame stabilizer is fabricated from stainless steel. The firing tube is 309 stainless steel (other alloys are available upon request). The firing tube and burner internal parts are easy to access and maintain.

The standard 4452 burner has NPT pipe threads for all gas connections. Air connections on the 4452-6 burners are threaded, while the 4452-7 and -8 include threaded companion flanges. The metric version features British Parallel pipe threads on all gas connections and on the air connections for the M4452-6 size. Welded companion flanges are supplied with the M4452-7 and -8.

## Lighting Arrangements

Burner ignition is provided by a direct spark igniter located on the main burner body. The burner should be turned to low fire with the spark turned on before opening the burner gas valve. After the burner is lit, the spark must be turned off for proper burner operation. During the ignition period, a continuous 6000 volt (minimum) spark is required. Spark distributor systems cannot be used reliably with 4452 Burners.

## Control And Adjustment

The 4452 burner fuel/air ratio can be controlled with a simple cross-connected ratio regulator such as the North American 7216. For firing rate control the burner can use conventional on-ratio turndown, StepFire™ or pulse firing. 4452 burners will not operate reliably with excess fuel.

Refer to Sheet 4452-3 for additional instructions and installation requirements. Accurate air/gas ratios can be determined by using 8697 Metering Orifices in the fuel and air lines.

## Flame Supervision

UV flame detectors or flame rods can be used with the 4452. A UV scanner applied to this burner will detect the direct igniter's spark. A UV-based flame supervision system must be designed to ignore this detection by use of an appropriate flame relay, or other code-compliant means, to prevent interruption of the ignition sequence. See Bulletin 8832 for choices of flame detectors and adapters or Parts List 4452-1 for applicable flame rod part numbers<sup>①</sup>. UV detector, adapter, and flame rod must be ordered separately.

## Mounting To Shell

The Burner must be attached to the shell of the furnace for support and sealed to avoid air infiltration. If air is allowed to leak between the furnace shell and the mounting flange NOx emissions could increase.

The burner is supplied with a "FGR" collector which helps maintain uniform FGR flow into the burner. The FGR collector flange is welded to the furnace shell and the burner mounted to the collector flange with pre-attached studs.

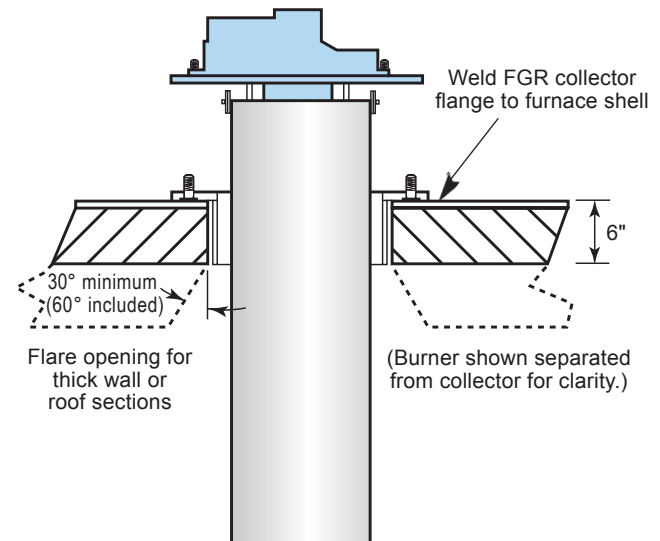

<sup>①</sup> Air cooled flame rods are suggested for applications above 1200°F or when the burner will operate at low fire for sustained periods. Low pressure combustion air, upstream of a control valve, is required. Air consumption will be approximately 100 scfh at 16 osi. A minimum of 12 osi is recommended.

## ORDERING INFORMATION

| Metric Version<br>"M" for metric<br>Leave blank for NPT threads | 4452 - |        | Air pipe size |        | Gas pipe size |                   | Air capacity,                    | Air capacity, |
|---|--------|--------|---------------|--------|---------------|-------------------|----------------------------------|---------------|
|   | Code   | inches | mm            | inches | mm            | scfh<br>at 16 osi | m <sup>3</sup> /hr<br>at 70 mbar |               |
|   | -6-A   | 3"     | 80            | 1½"    | 40            | 11,100            | 316                              |               |
|   | -6-B   | 3"     | 80            | 1½"    | 40            | 15,630            | 446                              |               |
|   | -7     | 4"     | 100           | 2"     | 50            | 26,180            | 747                              |               |
|   | -8-A   | 6"     | 150           | 2½"    | 65            | 36,360            | 1037                             |               |

Examples: 4452-6-A Low emissions gas burner  
M4452-7 Low emissions gas burner, metric

**WARNING:** Situations dangerous to personnel and property may exist with the operation and maintenance of any combustion equipment. The presence of fuels, oxidants, hot and cold combustion products, hot surfaces, electrical power in control and ignition circuits, etc., are inherent with any combustion application. Parts of this product may exceed 160F in operation and present a contact hazard. Fives North American urges compliance with National Safety Standards and insurance Underwriters recommendations, and care in operation.

Fives North American Combustion, Inc., 4455 East 71st Street, Cleveland, OH 44105 USA, Phone 216.271.6000  
Fax 216.641.7852 email: fna.sales@fivesgroup.com • www.fivesgroup.com/fivesna