

Adjustable Port Valves

for HOT or COLD AIR, GAS, OIL, WATER, STEAM

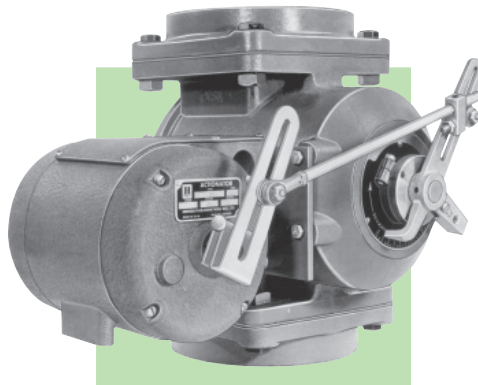

3" Adjustable Port Gas Valve
Beck Electric Operator



6" Adjustable Port Air Valve
Honeywell Electric Operator

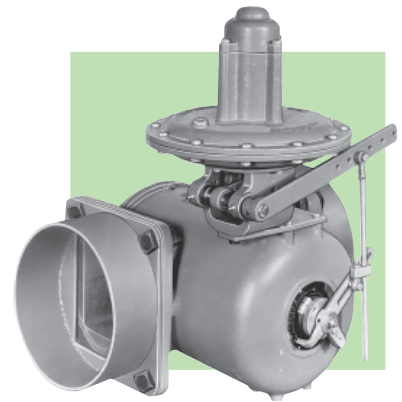

10" Adjustable Port Air Valve
N.A. Pneumatic Operator

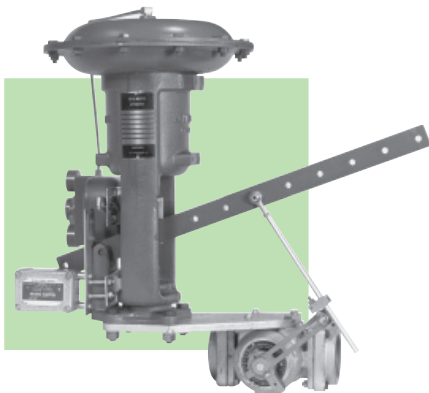

2½" Adjustable Port Air Valve
Honeywell Pneumatic Operator

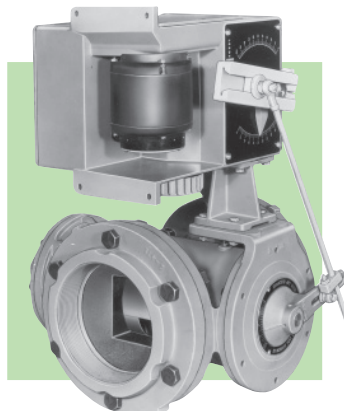

4" Adjustable Port Gas Valve
Honeywell Electric Operator

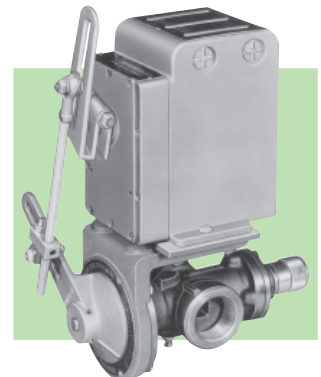

1¼" Adjustable Port Gas Valve
Barber-Colman Electric Operator

LOW TORQUE ● ROTARY PLUG ● EASILY CLEANED
pressure drop adjustable for best flow characteristic

Correct Valve Sizing Made Easy

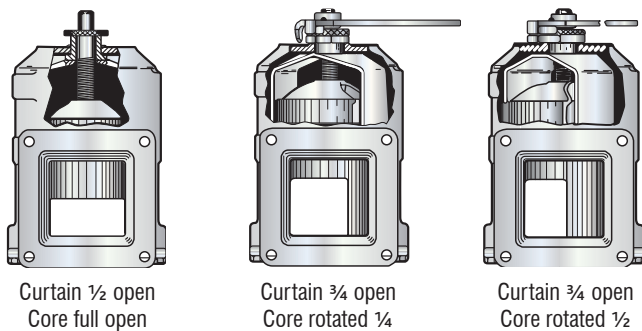

Figure A. Turning curtain adjusting knob changes port opening so valve can constitute optimum resistance in the system for good control.

For a valve operated by a modulating type control, either a linear or an equal percentage characteristic is preferred for most applications. These characteristics are shown in Figure B, together with two curves indicating very common but usually undesirable flow patterns: In their lower parts, change of flow is too fast, causing an "over correction;" while at the upper end there is practically no flow change in response to valve movements.

Shape of a flow curve depends (1) on valve **area characteristic**, and (2) on size of valve port relative to downstream resistances (piping, orifices, and burners), the sum of which is difficult to predict.

An Adjustable Port Valve solves the problem. Its linear area characteristic permits proper "sizing" of valve **after installation** without involved calculations.

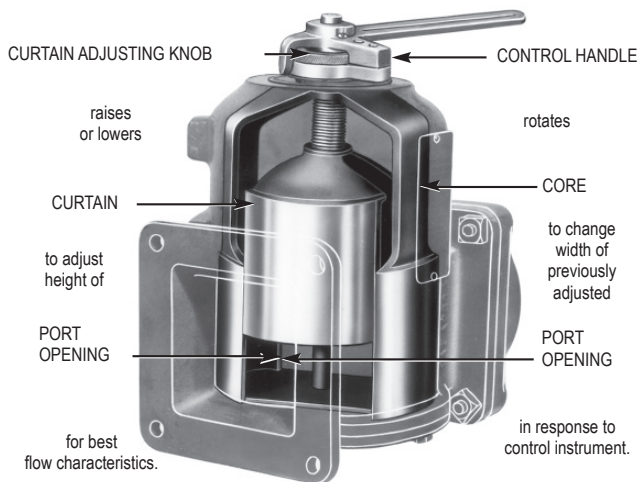

Figure C. Adjustable Port Valve for cold or hot air, 3 psi or less. All A.P. Valves have sliding gate action and rotary plug action.

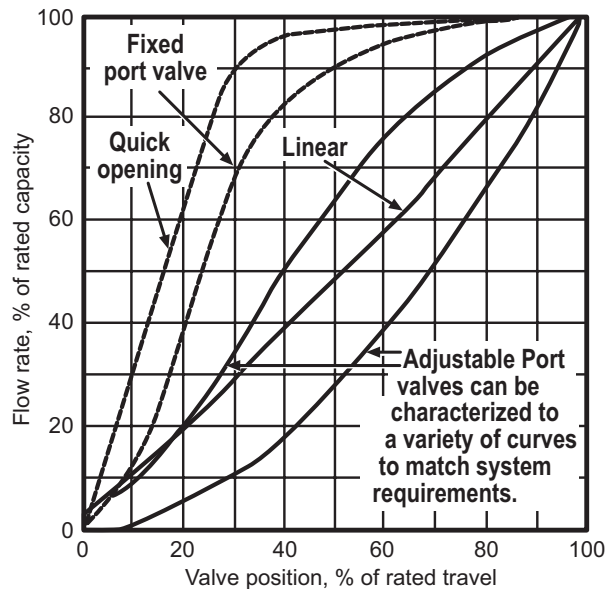

Figure B. Flow characteristics of valves installed in systems with downstream resistance. The three solid lines represent characterizable adjustable port valves.

Recommended procedure is to open valve control handle and valve curtain wide, then close curtain until pressure drop across valve is 1/5 to 1/6 of total system pressure drop. Flow characteristics shown as solid lines in **Figure B** can be realized with full valve stroke, enabling desired flow response to movements of the control motor.

Linkage between motor and valve can be "characterized" to produce the desired flow curve, e.g., linear or equal percentage.

Multiple Valve Combinations

Two or more Adjustable Port Valves can be used in combination to control air, fuel(s), and atomizing medium. In such combinations, valves can be "stacked" on a common shaft, or mounted side-by-side with linked control handles, or both.

A side-by-side arrangement generally allows more flexibility.

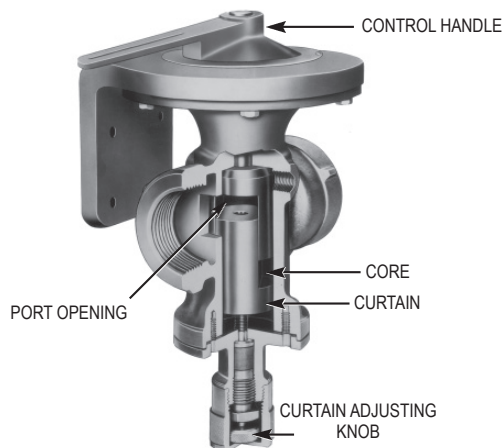

Figure D. A.P. Valve for gas, oil, water, steam, compressed air.

WARNING: Situations dangerous to personnel and property may exist with the operation and maintenance of any combustion equipment. The presence of fuels, oxidants, hot and cold combustion products, hot surfaces, electrical power in control and ignition circuits, etc., are inherent with any combustion application. Parts of this product may exceed 160F in operation and present a contact hazard. Fives North American Combustion, Inc. urges compliance with National Safety Standards and insurance Underwriters recommendations, and care in operation.