

The 5020-R4 Oxygen Burner offers the furnace designer many advantages. Flame is diffused which spreads heat over a wider area than other oxygen burners. Since there is no cooling water, the burner can be used on metal melting furnaces without fear of water/steam explosions. Choose from 5 different capacity ratings and 4 different heat patterns. A mounting bracket and tile simplifies installation. Mounting plates with tiles are available in both square and round versions.

Mounting construction similar to conventional air/gas burners locates the oxygen and gas lances away from furnace temperature and corrosive flux gases (where present). Maintenance is reduced compared with other oxygen burners. 5020-R4 Burners may be applied to processes up to 2500 F temperature.

A popular application is heating ladles. Oxygen's high temperature flame results in fast heating with time for deeper soaking of heat into the refractory. Results can be better quality metal, improved safety, extended refractory life, reduced electric costs, and increased productivity. (For complete information on ladle heating, contact your North American field engineer.)

Steel heating furnaces benefit from oxygen firing. Production increases occur with forge furnaces, soaking pits, and other steel reheat furnaces. Heating is fast but uniform because of 5020-R4's diffused flame.

Aluminum reverberatory melter production can be dramatically increased. If your operation is furnace constrained, 5020-R4 can be a less expensive solution to solving molten metal supply than buying and operating an additional furnace.

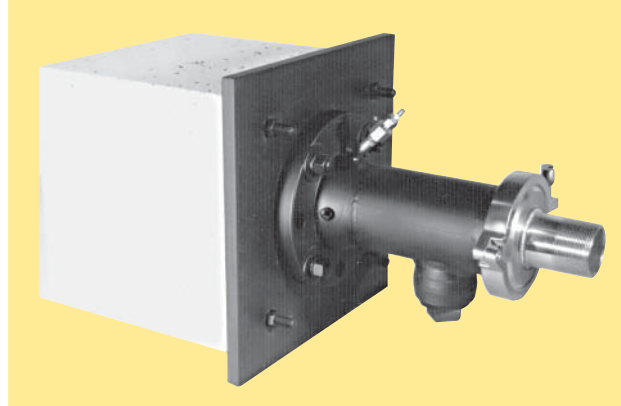

The burner can be direct spark ignited (igniter 4-18032) and monitored with ultraviolet flame supervision. Honeywell C7027A ultraviolet detectors have been used. Other sensors may be suitable but have not been tested. Use a heat block (Honeywell #136733) and NA 8836 Adapter with cooling air to minimize heat conducted to UV cell from burner.

You can specify design burner capacity and approximate flame length. The 5020-R4 is available with five capacity drillings with ratings from 6 to 10 mm Btu/h. The burner can be fired above

or below rating by changing oxygen and gas pressures. Two heat pattern nozzles produce flame lengths from long to medium long. Consult factory for nozzles with medium short and short flame lengths.

Firing a burner only at or below its rated capacity will avoid excessive combustion noise.

Burner Model	Nozzle Design Capacity (at 30 psig oxygen)
5020-R4	6 million Btu/hr 7 8 9 10

Heat Pattern Nozzle Number	Flame Length
1	Long
2	Medium Long

Burner	Nozzle heat pattern drilling #	Flame shape (approximate)		Burner pressure (at rated capacity)	
		Width (ft)	Length (ft)	Gas (psig)	Oxygen (psig)
5020-R4	1	1.5	11	0.4	30
	2	1.5	9	0.4	30

DIMENSIONS

inches

BURNER WITH SQUARE TILE

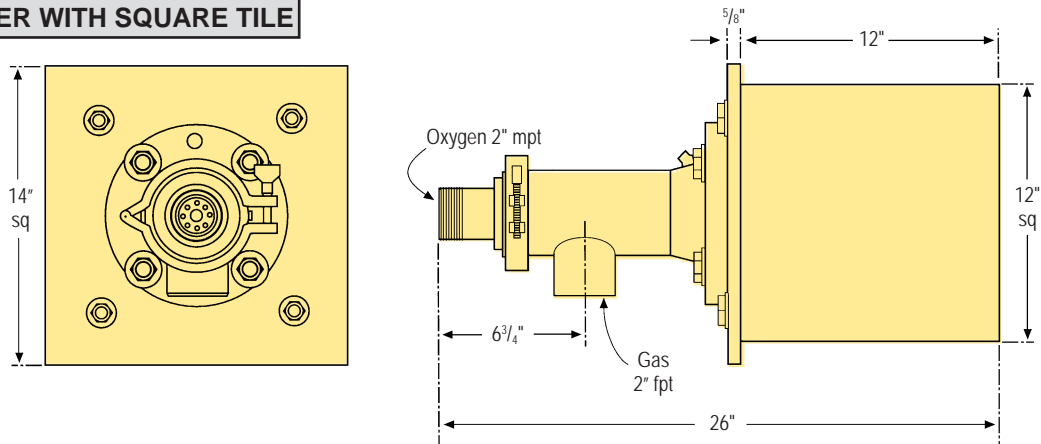

BURNER WITH ROUND TILE

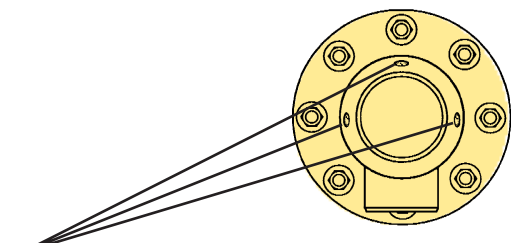
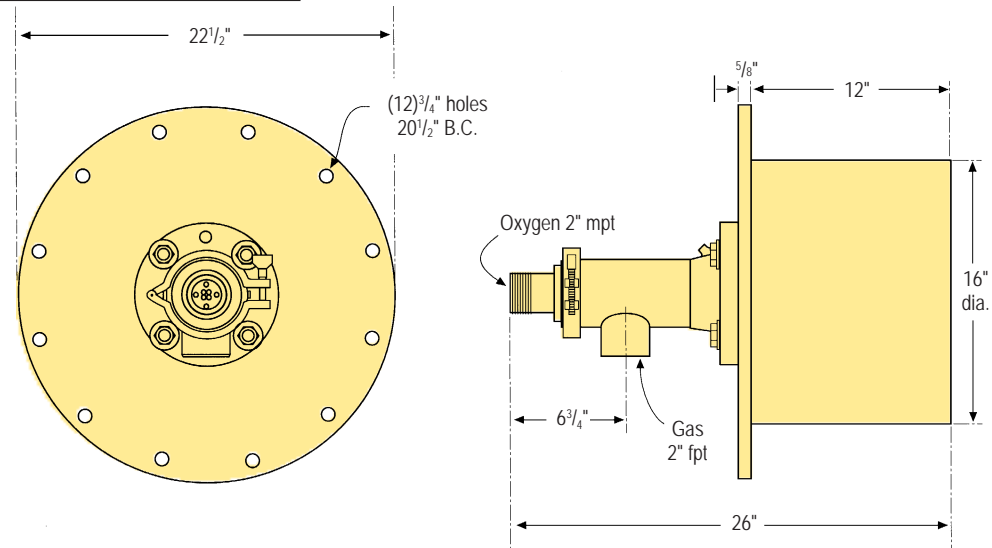

Three openings (1/4 NPT) can be used for UV detector, ignition electrode, and observation port.

DIMENSIONS SHOWN ARE SUBJECT TO CHANGE. PLEASE OBTAIN CERTIFIED PRINTS FROM FIVES NORTH AMERICAN COMBUSTION, INC.
IF SPACE LIMITATIONS OR OTHER CONSIDERATIONS MAKE EXACT DIMENSION(S) CRITICAL.

Ordering: Specify capacity in million Btu/hr, Tile shape (round or square), and nozzle number.

Example: 5020-R4-XX Burner complete, capacity 10 million Btu/hr, round tile, and #2 nozzle.

Spark Igniter: A4-18032

Patent 5,100,313: Manufactured under license from Praxair, Inc.

WARNING: All equipment and pipe used with oxygen must be made of suitable materials and properly cleaned for oxygen service. Operating personnel should be trained in oxygen safety procedures. Failure to do so could result in accidental injury or death. Contact your oxygen supplier and Fives North American for information.

WARNING: Situations dangerous to personnel and property may exist with the operation and maintenance of a combustion equipment. The presence of fuels, oxidants, hot and cold combustion products, hot surfaces, electrical power in control and ignition circuits, etc., are inherent with any combustion application. Parts of this product may exceed 160F in operation and present a contact hazard. Fives North American urges compliance with National Safety Standards and insurance Underwriters recommendations, and care in operation.

Fives North American Combustion, Inc., 4455 East 71st Street, Cleveland, OH 44105 USA, Phone 216.271.6000
Fax 216.641.7852 email: fna.sales@fivesgroup.com • www.fivesgroup.com/fivesna