

**4841 Hot Spot Gas Burners** produce ultra-short flames with some forward direction. They combine radiation and convection heating for improved overall efficiency. Unlike Flat Flame Burners, 4841 products of combustion have no sideward travel beyond the burner tile, so they transfer less heat to the walls.

**Hot Spot burners** provide precise flame direction and positioning. Among many applications they fire are:

**Slab and billet heaters.** Roof-mounted Hot Spots provide more hot gas velocity on the load.

**Spot heating of weldments and castings.** Ideal for building into automated equipment requiring compact heaters.

**Continuous frit smelters.** Hot Spot Burners provide radiation and convection heating for the charge end.

**4841 Burners** are sealed-in. Their flame diameter is about the same as the tile opening. Flame length with 16 osi air varies from 3" on the 4841-0 Burner to 18" on the -7, evidence of rapid heat release that permits burners to focus intense inputs in localized areas.

**Standard ratio control systems**, such as a cross connected atmospheric regulator, are suitable.

Hot Spot burners can be lit at high or low fire with a gas pilot, using a 4021-12 (spark-ignited) or 4021-11 (manual) tip. Operation is stable for air/gas ratios from stoichiometric to 20-70% excess air (depending on burner size and air pressure). Burners can run rich if there is free air in the combustion chamber. In a tight chamber, they must be set for about 20% excess air when chamber is cold during startup.

Ultraviolet flame supervision detectors are recommended for monitoring both main and pilot flames. An interrupted pilot must be used with flame supervision. Flame rods are not recommended.

Bodies and internals of 4841 burners are heat-resistant cast iron, as are mounting or cover plates for the smaller sizes (-0 thru -2). Sizes -3, -4, -5, -6, and -7 have fabricated steel mounting or cover plates. Burners with cover plates (flangeless) are designated 4841; burners with mounting plates (flanges) are ordered by specifying 4841- -F (flanged mounting not available for sizes 4841-0 and -1). The tile is a dense castable refractory suitable for service at furnace temperatures to 3000 F.

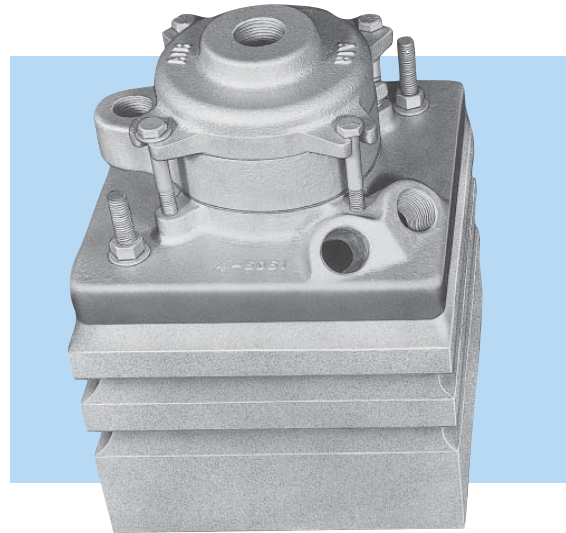
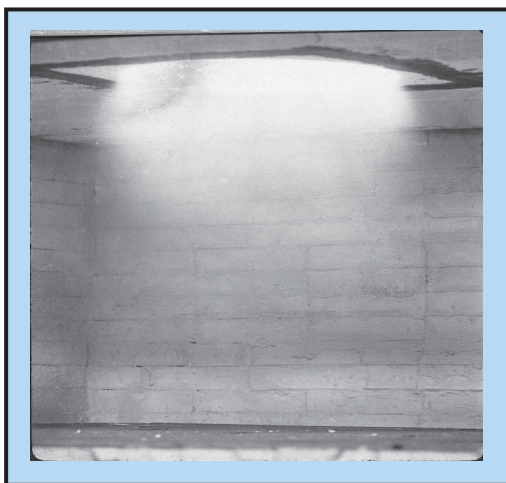

**Figure 1.** 4841-1 Hot Spot Burner with standard flangeless cover plate for installation in a furnace roof. There is no danger of flashback with this nozzle-mix burner.

**COMBUSTION AIR CAPACITIES, cfh**  
(for Btu/hr, multiply by 100)

Burner designation	air pressure drop across the Burner in osi				
	1	5	8	12	16
<b>4841-0</b>	194	435	550	670	775
<b>4841-1</b>	312	700	880	1 080	1 250
<b>4841-2</b>	550	1 230	1 550	1 900	2 200
<b>4841-3</b>	860	1 930	2 440	2 980	3 450
<b>4841-4</b>	1 490	3 340	4 220	5 150	5 950
<b>4841-5</b>	2 950	6 600	8 350	10 200	11 800
<b>4841-6</b>	3 750	8 400	10 600	13 000	15 000
<b>4841-7</b>	6 600	14 800	18 800	23 000	26 500
<b>4841-8-A†</b>	11 000	24 600	31 000	38 000	44 000
<b>4841-8-B†</b>	16 500	37 000	46 500	57 000	66 000

† See Sheet 4841-3 for information on these burners.



**Figure 2.** 4841-7 Hot Spot Burner focuses concentrated radiation heating on a specific hearth area.

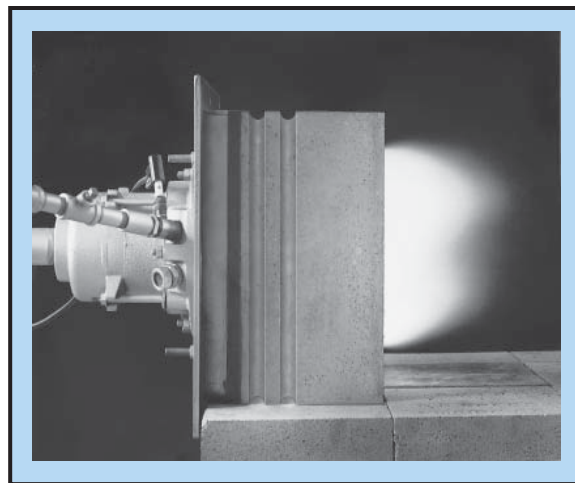

**Figure 3.** 4841-3-F Burner Flame--8" long with 12 psi air (298 000 Btu/hr). Optional flanged mounting<sup>①</sup> shown.

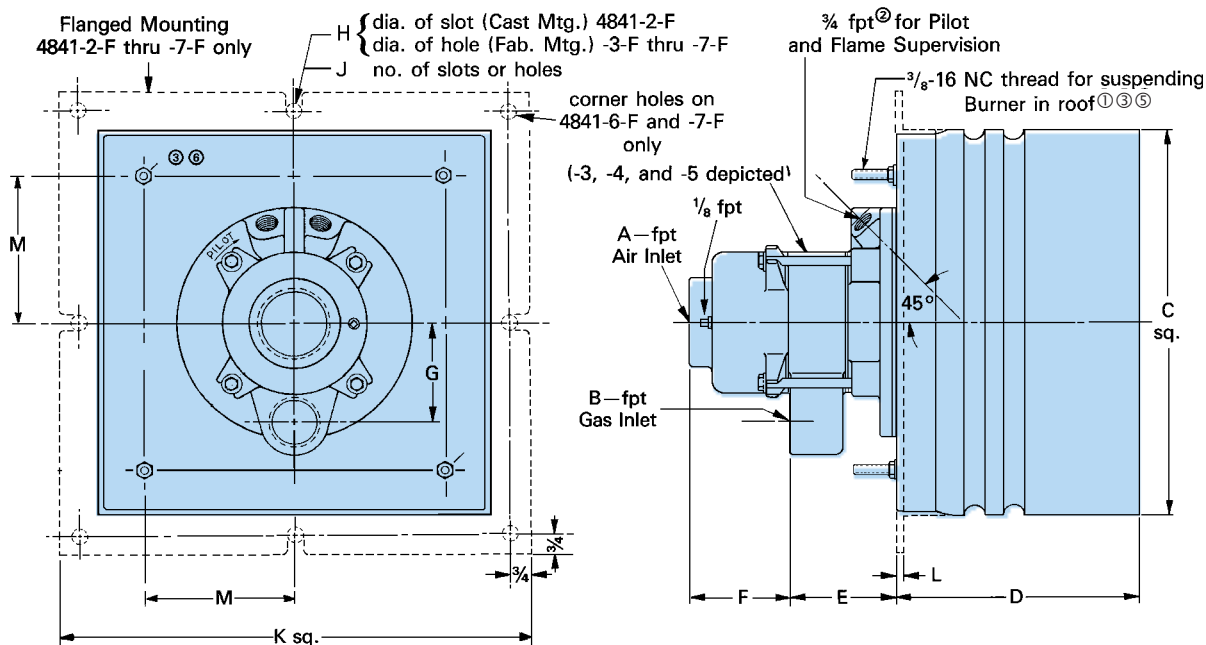

DIMENSIONS SHOWN ARE SUBJECT TO CHANGE. PLEASE OBTAIN CERTIFIED PRINTS FROM FIVES NORTH AMERICAN COMBUSTION, INC. IF SPACE LIMITATIONS OR OTHER CONSIDERATIONS MAKE EXACT DIMENSION(S) CRITICAL.

Burner designation	dimensions in inches											wt, lb	
	A	B	C	D	E	F	G	H	J	K	L		M
4841-0	3/4	1/2	7 1/2	7 1/8	1 29/32	1 3/4	2 3/4	—	—	—	—	3 5/16 <sup>③</sup>	42
4841-1	1	3/4	7 1/2	7 1/8	1 29/32	1 3/4	2 3/4	—	—	—	—	3 5/16 <sup>③</sup>	42
4841-2	1 1/4	3/4	9	7 1/8	1 29/32	1 3/4	2 3/4	5/8	4	12	3/8	3 1/4	54
4841-3	1 1/2	1	13 1/2	9 5/16	4 1/16	3 7/8	3 7/8	5/8	4	16 1/2	5/16	4 5/8	205
4841-4	2	1 1/4	15	9 5/16	4 1/16	3 7/8	3 3/4	5/8	4	18	5/16	5 3/4	230
4841-5	2 1/2	1 1/2	15	9 5/16	4 1/16	3 7/8	3 7/8	5/8	4	18	5/16	5 3/4	230
4841-6	3 <sup>④</sup>	2	18	9 3/8	4 3/16	7 1/4	5 3/8	5/8	8	21	3/8	6 1/2	250
4841-7	4 <sup>④</sup>	2 1/2	18	9 3/8	4 3/16	7 1/4	5 3/8	5/8	8	21	3/8	6 1/2	250

① Flanged Mounting is not recommended for roof installation because of difficulty packing around tile to prevent furnace leaks.

② For 4841-0 thru -2, both pilot and flame supervision connections are located as shown in Figure 1.

③ 4841-0 and -1 have only 2 studs.

④ Flanged air connection.

⑤ 4841-6 and -7 have 8 studs.

**WARNING:** Situations dangerous to personnel and property may exist with the operation and maintenance of any combustion equipment. The presence of fuels, oxidants, hot and cold combustion products, hot surfaces, electrical power in control and ignition circuits, etc., are inherent with any combustion application. Parts of this product may exceed 160F in operation and present a contact hazard. Fives North American Combustion, Inc. urges compliance with National Safety Standards and insurance Underwriters recommendations, and care in operation.