

Sealed-in Nozzle-Mix Burners for:

- controlled furnace atmosphere
- reliable operation
- excellent heat penetration

4545 Flame-Jet Burners are nozzle mixing, sealed-in gas burners of large capacity for use on installations ranging from low temperature air heaters and ovens to high temperature forging furnaces. They produce a penetrating jet of hot gases with high forward velocity. Flame-Jet burners operate dependably at air/gas ratios (listed in Table 2) ranging from excess air to excess fuel (with sufficient air for near-complete combustion in the furnace, supplied adjacent to the burners).

Design Features. The burners are made of relatively few, large parts that minimize maintenance problems. The internal flow passages are designed to give quiet operation. Air flows from a central orifice that is surrounded by an annular gas orifice. The result is a single jet flame of high forward velocity, causing heat to penetrate deeply into the furnace.

Because Flame-Jet burners are nozzle-mix, there is no possibility of flashback. The burner turndown is high, provided the control system is good enough to maintain correct air/gas ratio at very low firing rates.

Flame-Jet burners are suitable where control of furnace atmosphere is important and air infiltration is not desirable. The burners are tightly sealed, with threaded connections for the observation port, pilot, and flame rod adapter; the cast iron mounting plate is large enough to make a tight seal with the furnace wall; and the burner can be operated rich, lean, or on correct air/gas ratio, even against some backpressure in the combustion chamber.

A complete burner includes mounting plate, tile, and observation port, but does not include pilot tip or flame rod adapter which are optional extras. If no pilot or flame monitoring device is ordered with the burner, the openings for these devices are plugged and should be kept closed when not used.

Burner Operation. Flame-Jet burners, whether operating on natural or coke gas, require very little gas pressure at the burner, although higher gas pressures are an advantage for air/gas ratio control. The minimum required supply pressure for the gas is determined primarily by the pressure drop through the gas piping and accessories.

Flame-Jet burners may be lighted in hot or cold furnaces, at rich or lean air/gas ratios, by a North American 4011-12 Pilot Set.

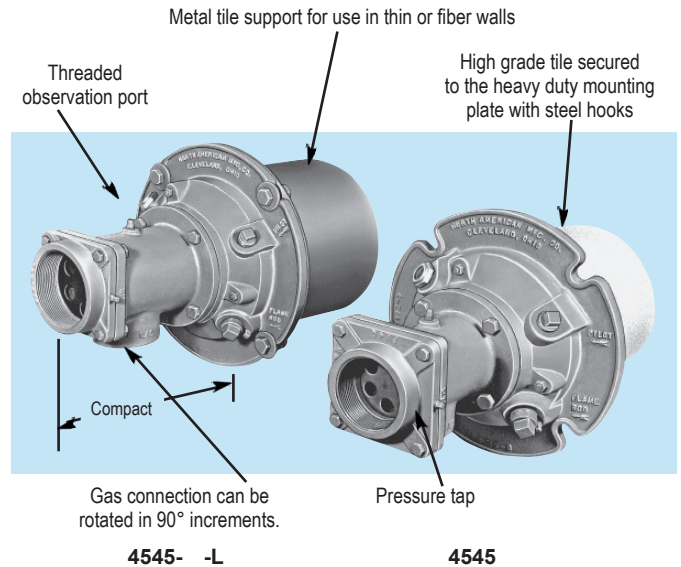

Flame Supervision. The stability of Flame-Jet burners permits any size to be operated with an interrupted pilot, which is strongly recommended. Either a flame rod or an ultraviolet detector can be used with -6 through -8-B sizes to monitor main flame when using an interrupted pilot. Use a UV detector with the 4545-9. Do not use a flame rod. A pilot flame just large enough to satisfy a flame rod will not light the -9 flame. When using flame supervision devices, 6 psi minimum pilot air pressure and low fire lighting are recommended. Ultraviolet detecting devices can be used with air/gas ratios within the range shown in Table 2.

Ground Rods. The main flame is not normally grounded, and thus requires ground rods to complete a circuit through a flame rod. Ground rods are not required with ultraviolet flame detectors. When using a flame rod, one ground rod is required with a 4545-6 or -7 Burner, and four rods with a -8-A or -8-B. The appropriate ground rods (7 1/2" long) are furnished at no extra cost when ordered with a burner.

Burner tiles are a dense castable that is good for 3200 F in the tile or about 2800 F furnace temperature. When the burner is shut off, continue air flow to protect the nozzle from furnace radiation. The cast tile has an expanded metal liner with welded mounting hooks. This unit is bolted to the heavy duty mounting plate. Bonding cement seals the joint. The uniform thickness of the cylindrical burner tiles greatly reduces the likelihood of thermal cracking.

Jacketed Tiles. 4545 Burners are available with metal support jackets around the tile for applications where the tile is not supported by furnace refractory.

Jackets are available in three different metals and have maximum temperature rating for each. They must be protected with sufficient insulation so as not to exceed rated temperature.

Maximum temperature rating for jacket metals depends upon frequency of heat-up/cool-down cycles. As an example, batch annealing furnaces that are heated and cooled every day should use the "intermittent exposure" ratings. Continuous annealing furnaces that remain at the same temperature for months at a time, can use the higher "continuous" rating.

Designation	Jacket metal	Continuous max. temp.	Intermittent exposure
4545- -LC	carbon steel	700 F	700 F
4545- -L4	304 stainless	1600 F	1500 F
4545- -L9	309 stainless	1900 F	1800 F

Table 1. Combustion air capacities, scfh (for Btu/hr, multiply by 100)

Burner designation	air pressure drop across the burner in osi						
	0.1	1	5	6	8	12	16
4545-6	1 180	3 710	8 300	9 100	10 500	12 800	14 800
4545-7	2 070	6 540	14 600	16 000	18 500	22 700	26 200
4545-8-A	3 350	10 600	23 700	26 000	30 000	36 700	42 400
4545-8-B	5 360	17 000	37 900	41 600	48 000	58 800	68 000
4545-9	9 840	31 100	69 600	76 200	88 000	108 000	124 000

Table 2. Flame characteristics with natural gas

Burner Size	Stability Limits			
	Air at burner, osi	excess air, %	excess fuel, %	flame length, feet
-6	1	160	75	2.5
	16	120	73	3.0
-7	1	480	100	3.0
	16	330	85	4.0
-8-A	1	270	100	4.0
	16	200	100	6.0
-8-B	1	300	100	4.5
	16	200	100	6.0
-9	1	1500	100	7.0
	16	1300	100	9.0

To order, specify: 4545-(code)-(A or B if applicable) (modifiers: LC, L4 or L9) burner complete

Examples: 4545-9 burner complete
4545-8-BL4 burner complete with 304 SST jacket

WARNING: Situations dangerous to personnel and property may exist with the operation and maintenance of any combustion equipment. The presence of fuels, oxidants, hot and cold combustion products, hot surfaces, electrical power in control and ignition circuits, etc., are inherent with any combustion application. Parts of this product may exceed 160F in operation and present a contact hazard. Fives North American urges compliance with National Safety Standards and insurance Underwriters recommendations, and care in operation.

Fives North American Combustion, Inc., 4455 East 71st Street, Cleveland, OH 44105 USA, Phone 216.271.6000
Fax 216.641.7852 email: fna.sales@fivesgroup.com • www.fivesgroup.com/fivesna