

DIMENSIONS
inches

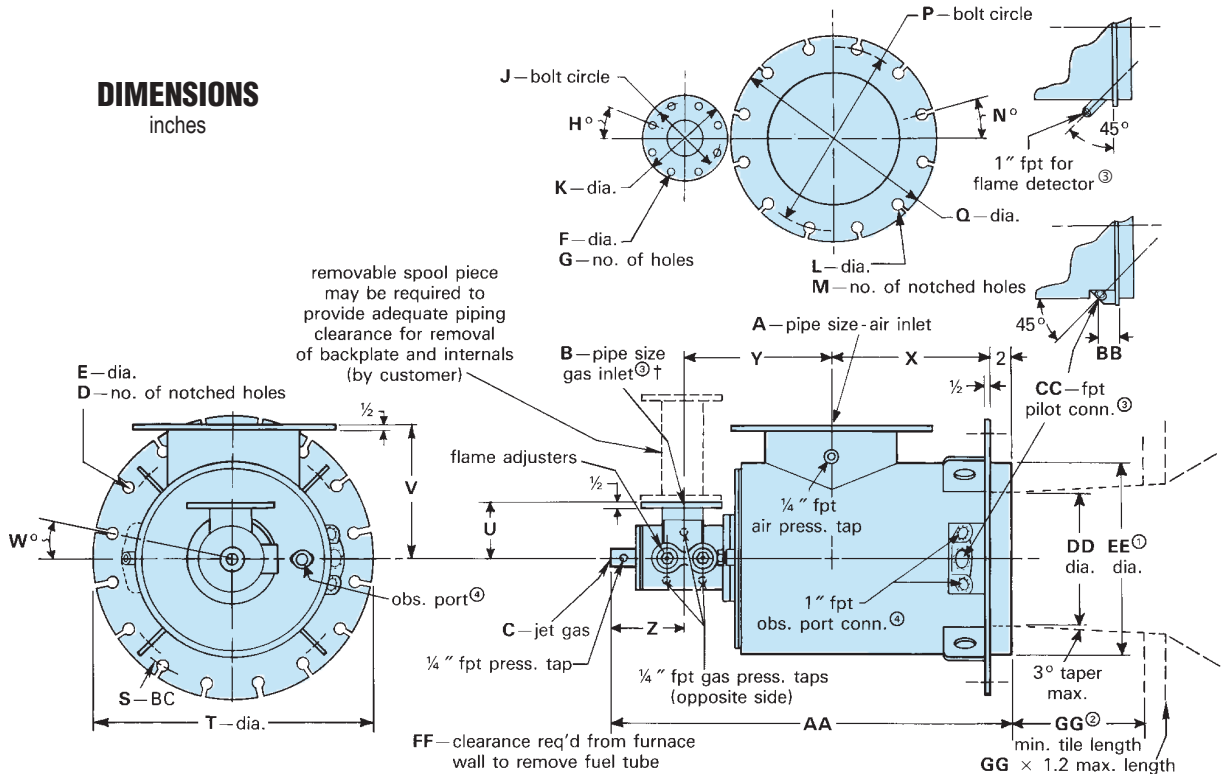

Burner designation	A ^③	B ^{③†}	C	D	E	F	G	H°	J	K	L	M	N°	P	Q	S	T	U
4472-8	6	2 1/2	3/4	16	3/4	-	-	-	-	-	7/8	8	22 1/2	9 1/2	11	24 1/2	26 1/4	5 1/8
4472-9	8	2 1/2	3/4	16	3/4	-	-	-	-	-	7/8	8	22 1/2	11 3/4	13 1/2	24 1/2	26 1/4	5 1/8
4472-10-A	10	2 1/2	3/4	20	3/4	-	-	-	-	-	1	12	15	14 1/4	16	26 1/2	28 1/4	5 1/8
4472-10-B	10	2 1/2	3/4	20	3/4	-	-	-	-	-	1	12	15	14 1/4	16	26 1/2	28 1/4	5 1/8
4472-12	12	2 1/2	3/4	20	3/4	-	-	-	-	-	1	12	15	17	19	28 1/2	30 1/4	5 1/8
4472-14	13 7/8	2 1/2	3/4	20	7/8	-	-	-	-	-	1 1/8	12	15	18 3/4	21	30 1/2	32 1/4	5 1/8
4472-16	15 7/8	2 1/2	3/4	24	7/8	-	-	-	-	-	1 1/8	16	11 1/4	21 1/4	23 1/2	32 1/2	34 1/4	5 1/8
4472-18	17 7/8	4	1	24	7/8	3/4	8	22 1/2	7 1/2	9	1 1/8	16	11 1/4	22 3/4	25	36 1/2	38 1/4	7 11/16
4472-20	19 7/8	4	1	24	7/8	3/4	8	22 1/2	7 1/2	9	1 1/4	20	9	25	27 1/2	38 1/2	40 1/4	7 11/16
4472-22	21 7/8	4	1	24	7/8	3/4	8	22 1/2	7 1/2	9	1 1/4	20	9	26	29 1/2	40 1/2	42 1/4	7 11/16
4472-24	23 7/8	4	1	24	7/8	3/4	8	22 1/2	7 1/2	9	1 3/8	20	9	29 1/2	32	42 1/2	44 1/4	7 11/16

† -8 thru -16, 2 1/2" threaded; -18 thru -24, 4" ANSI flange

Burner designation	V	W°	X	Y	Z	AA	BB	CC ^③	DD	EE ^①	FF	GG ^②	Pilot assembly designation
4472-8	13 1/2	11 1/4	16	12 3/4	7 3/8	38 1/8	2 3/16	1 1/4	14	20	63 5/8	11	4014-1-T
4472-9	13 1/2	11 1/4	16	12 3/4	7 3/8	38 1/8	2 3/16	1 1/4	14	20	63 5/8	11	4014-1-T
4472-10-A	14 1/2	9	18	14 3/8	7 3/8	41 3/8	2 3/4	1 1/2	16	22	70 7/8	13	4014-2-T
4472-10-B	14 1/2	9	18	14 3/8	7 3/8	41 3/8	2 3/4	1 1/2	16	22	70 7/8	13	4014-2-T
4472-12	15 1/2	9	20 1/2	15 7/8	7 3/8	45 3/4	2 7/8	2	18	24	79 1/8	14	4014-3-AT
4472-14	16 1/2	9	21 1/2	16 7/8	7 3/8	47 3/4	2 7/8	2	20	26	82 7/8	16	4014-3-AT
4472-16	17 1/2	7 1/2	22	17 1/2	7 3/8	48 7/8	2 7/8	2	22	28	85	18	4014-3-AT
4472-18	19 1/2	7 1/2	22 1/2	19 9/8	8 1/4	52 3/8	2 7/8	2	26	32	92 3/4	21	4014-3-BT
4472-20	21 1/2	7 1/2	23 1/2	20 1/2	8 1/4	54 1/4	2 7/8	2	28	34	93 1/2	22	4014-3-BT
4472-22	22 1/2	7 1/2	24 1/2	22 3/8	8 1/4	57 1/8	2 7/8	2	30	36	99 1/4	24	4014-3-BT
4472-24	23 1/2	7 1/2	25 1/2	23 1/2	8 1/4	59 1/4	2 7/8	2	32	38	103 1/2	26	4014-3-BT

① Furnace opening should be 1/2" larger than dimension EE for -8 thru -14; 3/4" larger than dimension EE for -16 thru -24.

② Any tile length greater than GG x 1.2 should have a 30° angled flare from the standard tile extension.

③ Burner must be ordered with pilot, gas, and flame detector locations designated. See reverse side.

④ Backplate and pilot observation ports included with burner.

Arrangement Designators are specified relative to the main air connection at 12 o'clock and should be listed for **pilot, gas, and flame detector in that order**. Good practice dictates that neither the pilot nor the flame supervision device be on the bottom of the burner.

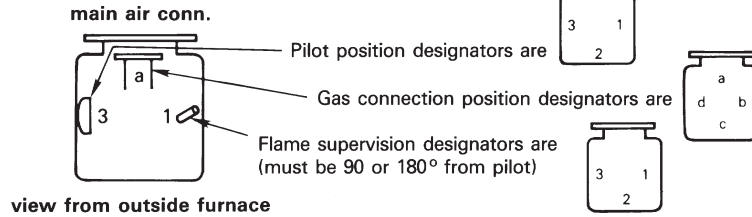

Burners are designed to be mounted no more than 15° from horizontal. Contact your North American Sales Engineer if your application requires a greater angle.

ATP Burner Tile Installation Recommendations for Hard Refractory Lined Furnaces

FIGURE 1

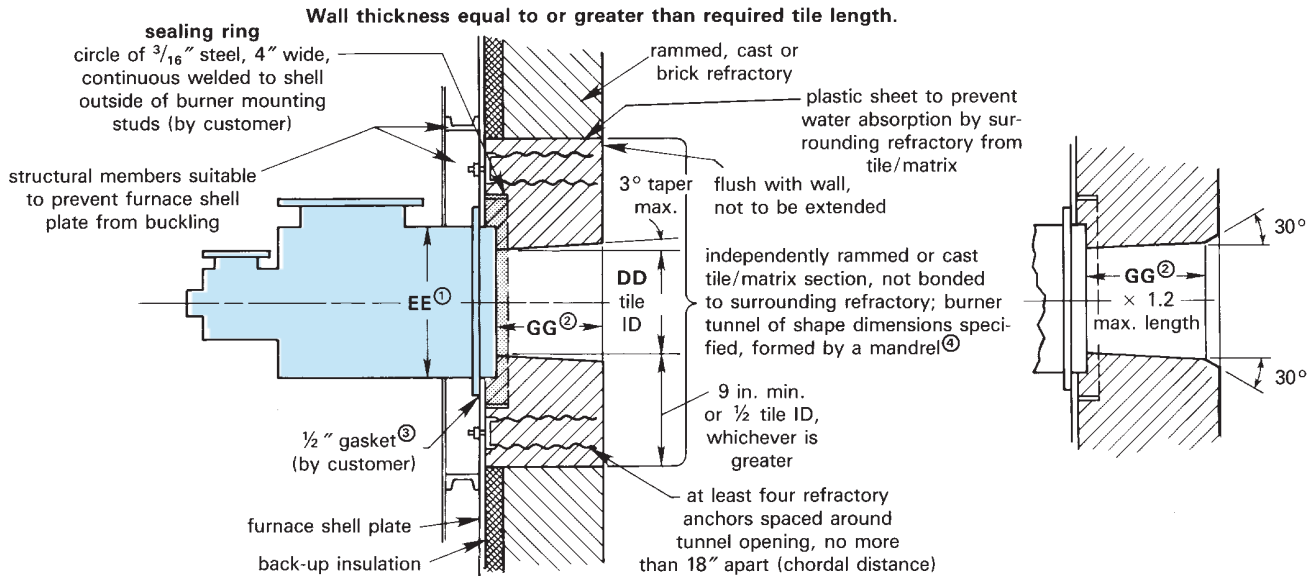
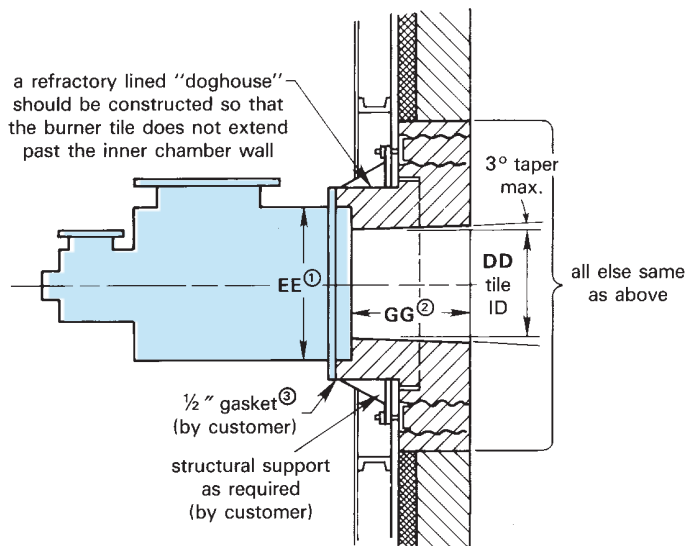

FIGURE 2

Wall thickness less than required tile length.



- ① Furnace opening should be $\frac{1}{2}$ " larger than dimension EE for -8 thru -14; $\frac{3}{4}$ " larger than dimension EE for -16 thru -24.
- ② Any tile length greater than $GG \times 1.2$ should have a 30° angled flare from the standard tile extension.
- ③ Two wraps of $\frac{1}{2}$ " soft fiberglass rope (Davlyn #100801 or equivalent) suitable for 1000 F service. North American can supply as part no. R540-0365. Specify length when ordering.
- ④ Expansion joints must be provided in surrounding refractory to prevent pressure being exerted on cast or rammed burner tunnel section.

WARNING: Situations dangerous to personnel and property may exist with the operation and maintenance of any combustion equipment. The presence of fuels, oxidants, hot and cold combustion products, hot surfaces, electrical power in control and ignition circuits, etc., are inherent with any combustion application. Parts of this product may exceed 160F in operation and present a contact hazard. Fives North American urges compliance with National Safety Standards and insurance Underwriters recommendations, and care in operation.

Fives North American Combustion, Inc., 4455 East 71st Street, Cleveland, OH 44105 USA, Phone 216.271.6000
Fax 216.641.7852 email: fna.sales@fivesgroup.com • www.fivesgroup.com/fivesna