

**Guide for installing burner tile in a fiber-lined furnace--maximum temperature 2200 F.** (See back for higher temperature applications and for all flat flame type burner tile installations.)

**Initial Installation (ref. Figure 1)**

1. Cut opening in furnace shell allowing clearance around tile or mounting plate lip. Check burner bulletin for recommended clearance (about 1/2").
2. Drill holes in furnace shell around opening to match burner mounting plate bolt holes.
3. Insert mounting bolts (G) (not provided) and weld heads to inside of furnace shell.
4. Weld channel stiffeners to outside of furnace shell as required.
5. Bolt mounting plate and tile to shell with gasket (F) in place if supplied.
6. Coat outside of tile with air setting refractory cement (C). Also, fill clearance gap between shell opening and tile with cement.
7. Wrap exposed tile length with continuous strip of blanket insulation (B) two layers thick.
8. Compress and secure wrap to tile, using a suitable non-metallic tape (E). Do not use string as it tends to cut the blanket. Compression of wrap should be at least 25%.
9. Install fiber insulation tightly against wrapped tile, following supplier's recommended procedure for anchoring and compressing fiber. All irregular-shaped sections must be packed with fiber.
10. For applications exceeding 2200 F furnace temperature, install ceramic fiber board shield as illustrated in Figures 2A and 2B.
11. **Important:** After initial firing of furnace at design temperature, check fiber shrinkage in vicinity of burner tile. Repack any voids with bulk fiber insulation to maintain a gas-tight seal between furnace interior and shell.

**Burner Tile Replacement**

On fiber-lined furnaces requiring tile replacement, fiber insulation near tile may prevent wrapping and fastening wrap as described in Steps 7 and 8 above. In such cases, the following procedure is recommended.

**Tile Replacement (refer to Figure 1)**

1. Bolt mounting plate and burner tile to shell with gasket (F) in place.
2. Coat outside of tile with air setting refractory cement (C). Also, fill clearance gap with cement.
3. Pack area between tile and furnace lining with bulk refractory fiber of a quality suitable for furnace design temperature. Compress bulk fiber at least 25% during packing.
4. Use a fiber board shield to retain the packed bulk fiber. (Refer to Figures 2A and 2B.)
5. Repeat Step 11 (check) above.

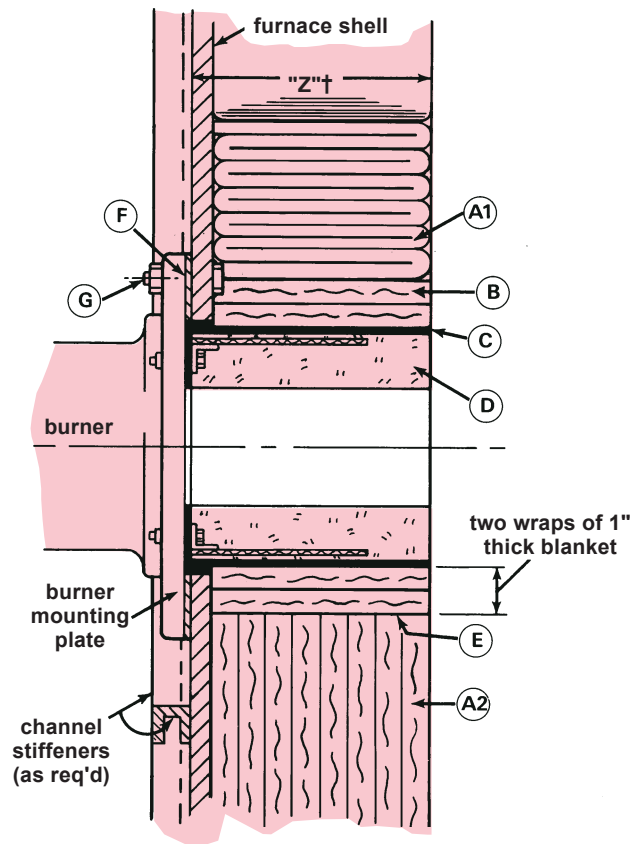

**Figure 1.** Cross section through a fiber-lined vertical furnace wall showing a recommended method for installing a burner tile. Letters refer to legend below and to text.

**Legend for Figure 1**

- (A<sub>1</sub>) Ceramic fiber modules. (Does not require "B" if modules are tight to burner.)
- (A<sub>2</sub>) Fiber type blanket, block, or board insulation.
- (B) Blanket insulation wrapped around tile. Use blanket 1" thick with at least 8 lb/ft<sup>3</sup> density and temperature rating equal to furnace lining.
- (C) High temperature, air setting refractory cement--thin wash coat.
- (D) Refractory Tile must be constructed specifically for fiber-lined furnaces. (Non-supported cast or prefired tiles usually are not suitable for fiber-lined furnaces).
- (E) Non-metallic fastening device (tape, rope, plastic, cheesecloth, etc.) to compress and secure wrapped blanket about tile.
- (F) Gasket: to provide a seal between burner mounting plate and furnace shell.
- (G) Burner mounting bolts with heads welded to inside of furnace shell.

† "Z" dimension is tile insertion length. North American burner tiles for fiber-lined furnaces are available with "Z" dimensions in 1/2" increments from 2" minimum to full tile length.

## INSTALLATION EXCEEDING 2200 F

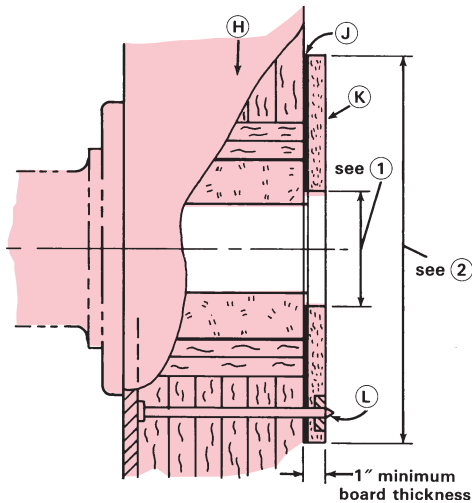

**Figure 2A.** Fiber board shield installation for applications exceeding 2200 F (see Figure 2B for flat flames).

### Legend for Figure 2A

- (H) Installation as shown in Figure 1.
- (J) High temperature, air setting refractory cement wash coat.
- (K) Ceramic fiber board shield suitable for furnace design temperature.
- (L) Ceramic anchoring device.

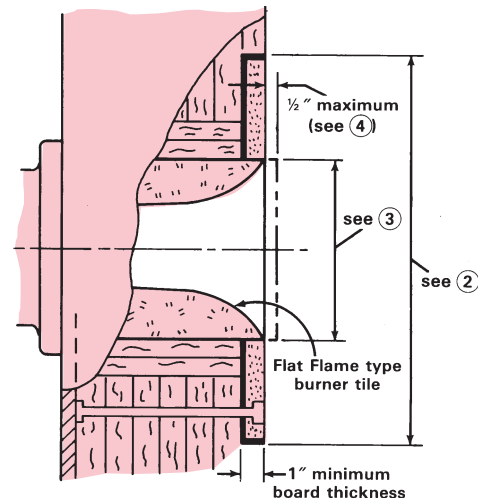
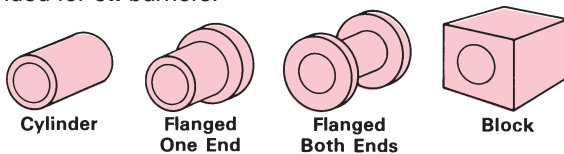

**Figure 2B.** Fiber board shield for all flat flame type burner tile installations.

- ① Port clearance hole--at least 1" larger in diameter than tile port diameter.
- ② Fiber board shield can be round or square--equal to at least twice tile diameter or width.
- ③ Shield hole must be cut to provide snug fit. Coat all edges and inner face with high temperature, air setting refractory cement.
- ④ Flat flame burner tile face must never be recessed into furnace wall. It must be flush or less than 1/2" extended into furnace beyond adjacent ceramic fiber board. Configurations are available with proper mounting flange placement to accomplish this (see "Z" dimension note in Figure 1). If burner tiles do not have variable "Z" dimension option, burner must be recessed into or extended out from furnace wall to maintain hot face position requirement (see Supplement DF-M1, Figure 1B).

## CERAMIC FIBER BURNER TILES

Fiber burner tiles are offered in a variety of shapes and designs, as illustrated below. Fiber tiles are **not** recommended for oil burners.

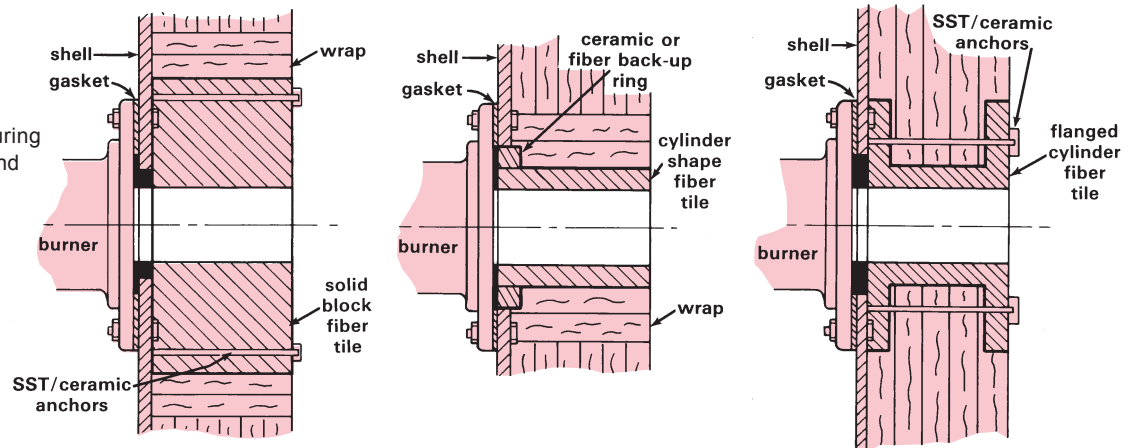

**Figure 3.** Common fiber tile shapes. Flanges may be round or square.

### NOTE:

1. Using high temperature, air setting refractory cement, coat all surfaces of fiber tile shape that are in contact with burner, shell, or furnace lining. Fill all voids.
2. Fiber tile surfaces can be pierced and/or compressed to accommodate burner mounting bolt heads and anchoring protrusions.
3. If possible, wrap fiber tile with blanket insulation as shown in Figure 1.

**Figure 4.** Methods of securing fiber tile shapes to burners and furnace walls.



**WARNING:** Situations dangerous to personnel and property may exist with the operation and maintenance of any combustion equipment. The presence of fuels, oxidants, hot and cold combustion products, hot surfaces, electrical power in control and ignition circuits, etc., are inherent with any combustion application. Parts of this product may exceed 160F in operation and present a contact hazard. Fives North American urges compliance with National Safety Standards and insurance Underwriters recommendations, and care in operation.