

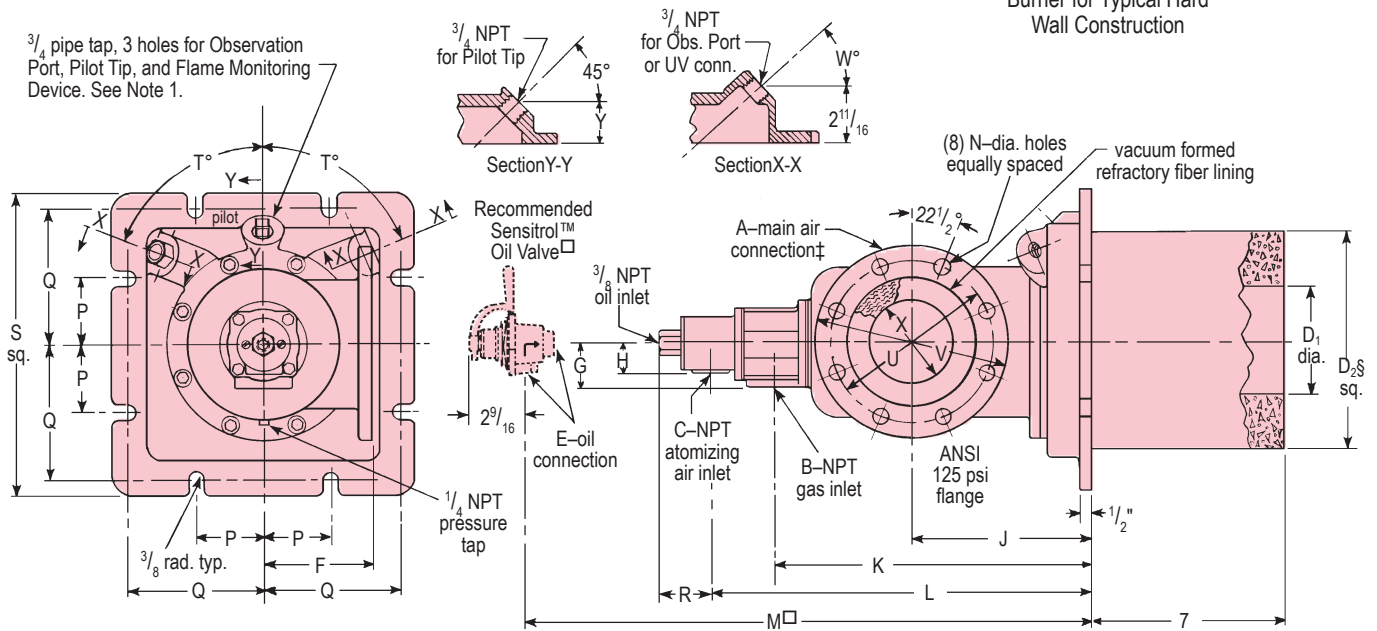

**DIMENSIONS**

in inches

Burner for Typical Hard Wall Construction



Main air is drawn at 3 o'clock for convenience in showing flange dimensions, but arrangement designators are specified relative to main air at 12 o'clock. Thus the dimension drawing portrays a 3bf arrangement. (See Bulletin 6825 re arrangement designators.)

**NOTE:**

1. Pilot must be located in center hole and at least 90 degrees from the main air inlet. Position selected should not place the pilot, observation port, and flame monitoring adapter boss in a bottom quadrant of the burner when installed.

Burner designation	dimensions in inches													
	A ‡	B	C	D <sub>1</sub>	D <sub>1</sub> §	E	F	G	H	J	K	L	M □	N
6825-2	4	1	3/4	4	10	1/4	5	2	1 3/8	8 5/16	14 11/16	17 5/8	24 5/16	3/4
6825-3	4	1	3/4	4	10	1/4	5	2	1 3/8	8 5/16	14 11/16	17 5/8	24 5/16	3/4
6825-4	4	1 1/4	3/4	4	10	1/4	5	2	1 3/8	8 5/16	14 11/16	17 5/8	24 5/16	3/4
6825-5	4	1 1/2	1	5	10	3/8	5	2	1 3/8	8 5/16	14 11/16	17 5/8	24 5/16	3/4
6825-6	4	1 1/2	1	5	10	3/8	5	2	1 3/8	8 5/16	14 11/16	17 5/8	24 5/16	3/4
6825-7-A	6	2 1/2	2	7	12	3/8	7	2 5/8	1 3/4	9 5/16	17 11/16	21 7/8	29 9/16	7/8
6825-7-B	6	2 1/2	2	7	12	3/8	7	2 5/8	1 3/4	9 5/16	17 11/16	21 7/8	29 9/16	7/8
6825-8-A	6	2 1/2	2	7	12	3/8	7	2 5/8	1 3/4	9 5/16	17 11/16	21 7/8	29 9/16	7/8

Burner designation	dimensions in inches and degrees										Recommended Sensitrol Oil Valve □	Wt, lb
	P	Q	R	S	T°	U	V	W°	X	Y		
6825-2	3 1/8	6 1/4	2 5/16	14	67 1/2	7 1/2	9	42	4	1 29/32	1813-03	175
6825-3	3 1/8	6 1/4	2 5/16	14	67 1/2	7 1/2	9	42	4	1 29/32	1813-03	175
6825-4	3 1/8	6 1/4	2 5/16	14	67 1/2	7 1/2	9	42	4	1 29/32	1813-03	175
6825-5	3 1/8	6 1/4	2 5/16	14	67 1/2	7 1/2	9	42	4	1 29/32	1813-02-A	175
6825-6	3 1/8	6 1/4	2 5/16	14	67 1/2	7 1/2	9	42	4	1 29/32	1813-02-A	175
6825-7-A	3 11/16	7 3/8	2 3/4	16	58 1/2	9 1/2	11	34 1/2	6	1 13/16	1813-02-B	230
6825-7-B	3 11/16	7 3/8	2 3/4	16	58 1/2	9 1/2	11	34 1/2	6	1 13/16	1813-02-B	230
6825-8-A	3 11/16	7 3/8	2 3/4	16	58 1/2	9 1/2	11	34 1/2	6	1 13/16	1813-02-C	230

‡ Except for -8-A, use supply piping with oversized flange.

§ Furnace opening should be 1/2" larger than dimension D<sub>2</sub>.

□ Piping not furnished by North American. Dimension M assumes the use of a close nipple between burner and Sensitrol. Optional (recommended) Sensitrol Oil Valve is not included as part of the burner assembly, and must be ordered separately.

# DIMENSIONS

in inches

## Burner for Typical Fiber

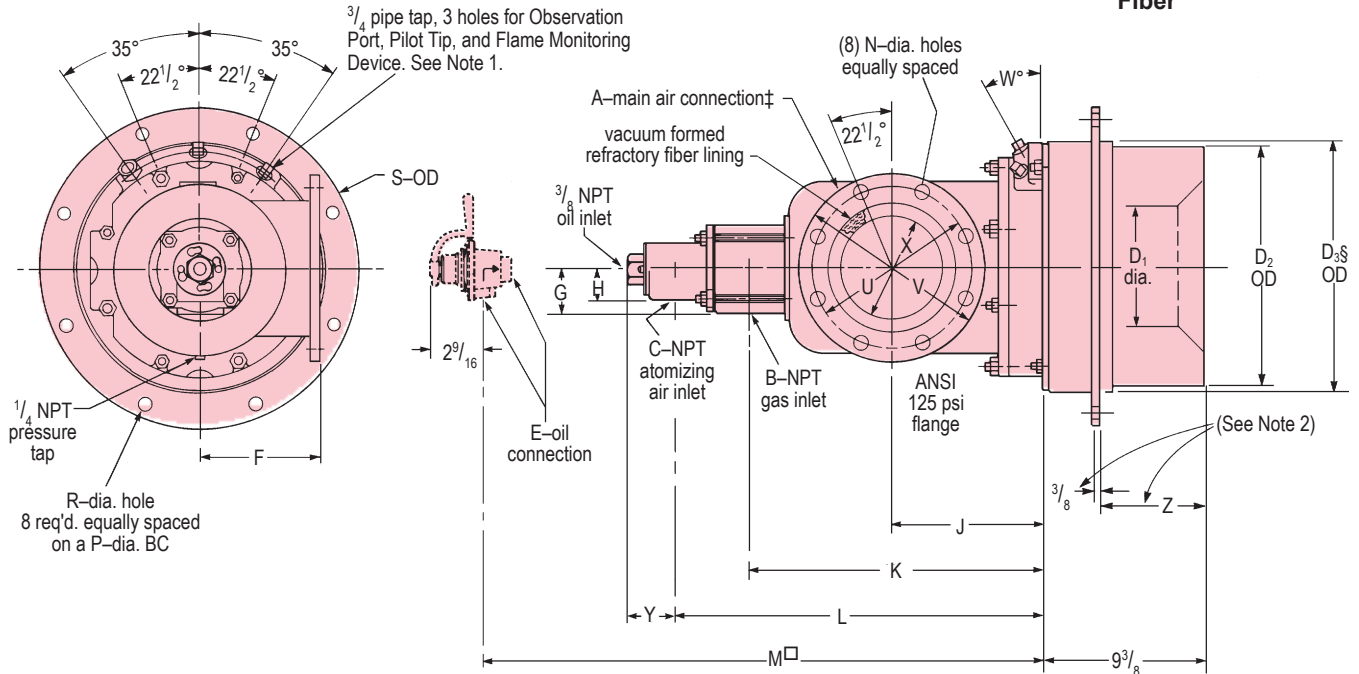

Main air is drawn at 3 o'clock for convenience in showing flange dimensions, but arrangement designators are specified relative to main air at 12 o'clock. Thus the dimension drawing portrays a 3bf arrangement. (See Bulletin 6825 re arrangement designators.)

**NOTE:**

1. Pilot must be located in center hole and at least 90 degrees from the main air inlet. Position selected should not place the pilot, observation port, and flame monitoring adapter boss in a bottom quadrant of the burner when installed.
2. "Z" dimension variable from 2" to 9" by 1/2" increments for fiber wall construction. When "Z" dimension is equal to 9" the backplate and mounting flange will be one piece.

Burner designation	dimensions in inches														
	A‡	B	C	D <sub>1</sub>	D <sub>2</sub>	D <sub>3</sub> §	E	F	G	H	J	K	L	M□	N
6825-2	4	1	3/4	4	11 3/8	12	1/4	5	2	1 3/8	7 7/8	14 1/4	17 3/16	23 7/8	3/4
6825-3	4	1	3/4	4	11 3/8	12	1/4	5	2	1 3/8	7 7/8	14 1/4	17 3/16	23 7/8	3/4
6825-4	4	1 1/4	3/4	4	11 3/8	12	1/4	5	2	1 3/8	7 7/8	14 1/4	17 3/16	23 7/8	3/4
6825-5	4	1 1/2	1	5	11 3/8	12	3/8	5	2	1 3/8	7 7/8	14 1/4	17 3/16	23 7/8	3/4
6825-6	4	1 1/2	1	5	11 3/8	12	3/8	5	2	1 3/8	7 7/8	14 1/4	17 3/16	23 7/8	3/4
6825-7-A	6	2 1/2	2	7	14	14 5/8	3/8	7	2 5/8	1 3/4	9	17 3/8	21 9/16	29 1/4	7/8
6825-7-B	6	2 1/2	2	7	14	14 5/8	3/8	7	2 5/8	1 3/4	9	17 3/8	21 9/16	29 1/4	7/8
6825-8-A	6	2 1/2	2	7	14	14 5/8	3/8	7	2 5/8	1 3/4	9	17 3/8	21 9/16	29 1/4	7/8

Burner designation	dimensions in inches and degrees								Recommended Sensitrol Oil Valve□	Wt, lb
	P	R	S	U	V	W°	X	Y		
6825-2	14 1/2	5/8	16	7 1/2	9	45	4	2 5/16	1813-03	175
6825-3	14 1/2	5/8	16	7 1/2	9	45	4	2 5/16	1813-03	175
6825-4	14 1/2	5/8	16	7 1/2	9	45	4	2 5/16	1813-03	175
6825-5	14 1/2	5/8	16	7 1/2	9	45	4	2 5/16	1813-02-A	175
6825-6	14 1/2	5/8	16	7 1/2	9	45	4	2 5/16	1813-02-A	175
6825-7-A	17	3/4	18 5/8	9 1/2	11	30	6	2 3/4	1813-02-B	230
6825-7-B	17	3/4	18 5/8	9 1/2	11	30	6	2 3/4	1813-02-B	230
6825-8-A	17	3/4	18 5/8	9 1/2	11	30	6	2 3/4	1813-02-C	230

‡ Except for -8-A, use supply piping with oversized flange.

§ Furnace opening should be 1/2" larger than dimension D<sub>3</sub>.

□ Piping not furnished by North American. Dimension M assumes the use of a close nipple between burner and Sensitrol. Optional (recommended) Sensitrol Oil Valve is not included as part of the burner assembly, and must be ordered separately.

DIMENSIONS SHOWN ARE SUBJECT TO CHANGE. PLEASE OBTAIN CERTIFIED PRINTS FROM FIVES NORTH AMERICAN COMBUSTION, INC. IF SPACE LIMITATIONS OR OTHER CONSIDERATIONS MAKE EXACT DIMENSION(S) CRITICAL.

**WARNING:** Situations dangerous to personnel and property may exist with the operation and maintenance of any combustion equipment. The presence of fuels, oxidants, hot and cold combustion products, hot surfaces, electrical power in control and ignition circuits, etc., are inherent with any combustion application. Parts of this product may exceed 160F in operation and present a contact hazard. Fives North American Combustion, Inc. urges compliance with National Safety Standards and insurance Underwriters recommendations, and care in operation.