

DESCRIPTION, CAPACITIES, SPECIFICATIONS, APPLICATIONS

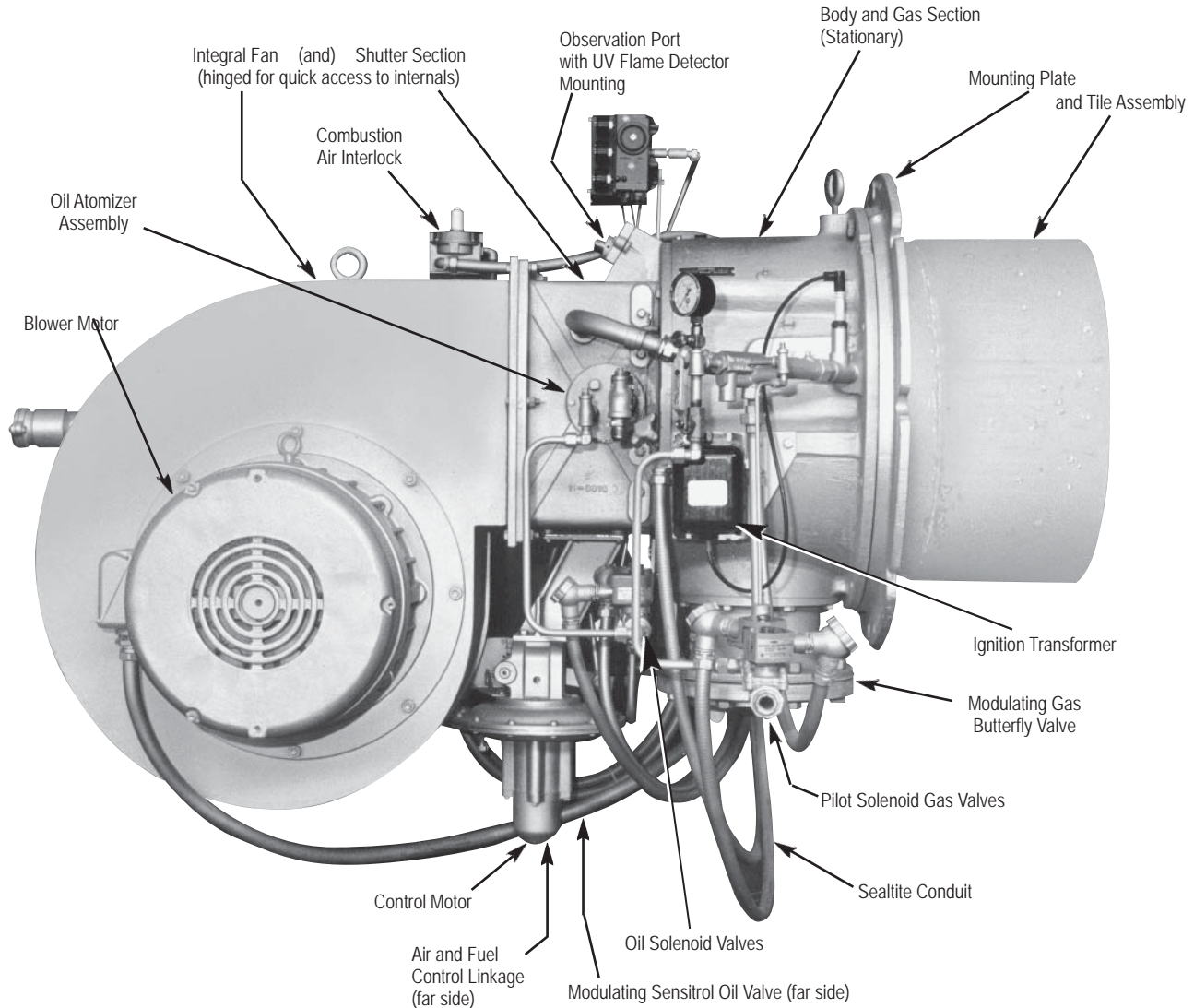

Features of NORTH AMERICAN Integral Fan Burners

BUILT-IN FAN: Delivers 100% of combustion air required for burner operation. Eliminates need to install an expensive and bulky air delivery system. Avoids dependency of several burners on one blower.

CONTROL VARIETY: Building from the basic burner package, two ratio control systems are available along with many pre-packaged gas and oil trains, motorized controls, flame safeguard accessories, and programming systems.

WIDE RANGE OF CAPACITIES: 3 000 000 to 30 000 000 Btu/hr, in seven sizes. Typical air turndown is 4:1 on standard models. Greater turndowns are available for special applications.

RUGGED, VERSATILE, AND RELIABLE: An ultra stable burner designed to operate with 20% excess air in chambers at temperatures up to 2000 F and under negative or slightly positive pressures. Cold, tight chambers present no problem for this rugged, low-maintenance workhorse. Proven reliability while operating with natural gas, any grade of commercial fuel oil, crude oil, pitch, or refinery bottoms.

LOW NO_x: By their design the package burners are inherently Low No_x. In conjunction with other NO_x reducing features, they are capable of meeting emission limitations for new or retrofit applications in environmentally sensitive installations. However, emission levels will vary from one application to another. Contact your Fives North American for your specific application.

BURNER DESIGNATION ^①	Main air, Btu/hr	CAPACITIES ^②		Flame Size, gph ^③	CHARACTERISTICS		BLOWER	
		Natural gas, scfh	Oil, gas, scfh ^③		dia.	length	hp	rpm
4131A	4 200 000	50 000	4 200	-	2.5' × 5'	1.5	3450	
5131A- { 2	4 200 000	50 000	-	30.3	2.5' × 5'	1.5	3450	
6131A- { 5,6	4 200 000	50 000	4 200	27.9	2.5' × 5'	1.5	3450	
CR	4 200 000	50 000	4 200	27.9	2.5' × 5'	1.5	3450	
4131B	6 300 000	76 000	6 300	-	3' × 7'	3	3450	
5131B- { 2	6 300 000	76 000	-	50.7	3' × 7'	3	3450	
6131B- { 5,6	6 300 000	76 000	6 300	42.0	3' × 7'	3	3450	
CR	6 300 000	76 000	6 300	42.0	3' × 7'	3	3450	
5131CL- { 4	10 500 000	126 000	-	78	3.5' × 11'	5	1750	
6131CL- { 5,6	10 500 000	126 000	10 500	70	3.5' × 11'	5	1750	
4131C { ④	12 300 000	141 000	12 300	-	3.5' × 12'	5	3450	
5131C- { 2④	12 300 000	141 000	-	91	3.5' × 12'	5	3450	
6131C- { 5,6	8 400 000	105 000	8 400	55.8	3.5' × 12'	5	3450	
4131CS { ⑤	8 400 000	105 000	8 400	-	3.5' × 12'	7.5	3450	
5131CS- { 2⑤	8 400 000	105 000	-	55.8	3.5' × 12'	7.5	3450	
6131CS- { 2⑤	8 400 000	105 000	8 400	55.8	3.5' × 12'	7.5	3450	
4131D { 2	18 000 000	216 000	18 000	-	4' × 12'	7.5	1750	
5131D- { 2	18 000 000	216 000	-	131	4' × 12'	7.5	1750	
6131D- { 5,6	16 800 000	200 000	16 800	112	4' × 12'	7.5	1750	
4131E { 2	25 200 000	300 000	25 200	-	4' × 12'	10	1750	
5131E- { 2	25 200 000	300 000	-	182	4' × 12'	10	1750	
6131E- { 5,6	25 200 000	300 000	25 200	167	4' × 12'	10	1750	
CR	25 200 000	300 000	25 200	167	4' × 12'	10	1750	
4131FA { 2	30 000 000	360 000	30 000	-	4' × 18'	20	3450	
5131FA- { 2	30 000 000	360 000	-	222	4' × 18'	20	3450	
6131FA- { 5,6	30 000 000	360 000	30 000	200	4' × 18'	20	3450	
CR	30 000 000	360 000	30 000	200	4' × 18'	20	3450	

① Burner model number breakdown is as follows:

First digit identifies burner as—

- 4 = gas only
- 5 = oil only
- 6 = dual-fuel

Next 3 digits, 131, identify burner as part of integral fan series

Letters designate burner frame size

Numerals or CR after hyphen show fuel selection—

- 2 = #2 or #4 oil
- 5 = #5 oil
- 6 = #6

CR = crude oil

② Capacities and flame lengths are with 20% excess air and 1.5"wc backpressure in a cold, tight chamber. Excess air operation at rates greater than 20%, through reduction of fuel input, is possible for nearly all of these burners. Consult factory for maximum excess air rate for any particular size and fuel.

③ Fuel rates are based on the following calorific values:

- 1 000 Btu/cu ft of natural gas
- 135 000 Btu/gallon of light (#2 or #4) oil
- 150 000 Btu/gallon of heavy (#5 or #6) oil
- 145 000 Btu/gallon of crude oil

④ Capacity is with 15% excess air and 0.5"wc backpressure.

⑤ Capacity is with 20% excess air and 5"wc backpressure.

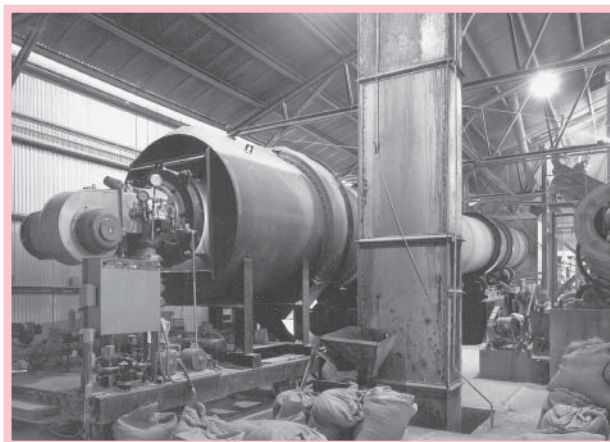

Sand Dryer



Heater Treater

APPLICATIONS

Process Heaters
Steam Generators
Emulsion Treaters
Direct-Fired Oil Heaters

Water Heaters
Core Dryers
Paint Dryers
Ceramic Dryers

Liquid Asphalt Heaters
Boilers
Vaporizers
Dross Reclaiming Furnaces

Aluminum Melters
Incinerators
Air Heaters
Rotary Dryers for Ore, Sand, or Aggregate

SPECIFICATIONS

Integral fans provide 100% combustion air to these nozzle-mix burners. Oil atomizers are of the tip emulsion design, using steam or compressed air as the atomizing medium. Oil must be delivered to the nozzle at viscosities below 100 SSU.

The ruggedly constructed burners consist of three basic sections.

Front Section. A heavy cast iron mounting plate, with slotted mounting holes, fitted with a high strength castable burner tile rated for service up to 2600 F. A carbon steel or 304 stainless steel tile support jacket is available as an option.

Center Section. A circular gas plenum with bottom gas inlet, a combustion air diffuser, a connection for a spark-ignited premix gas pilot (for natural gas or propane), and a threaded boss to accommodate a flame rod.

Rear Section. Hinge-mounted includes blower motor, impeller, intake guard, a large reinforced glass observation port, provisions for mounting a flame detector, the flange-mounted oil atomizer, and the manual or motorized firing rate control. An accurate linked valve ratio control is provided by a compact arrangement of linkage rods and swivels that connect the internal main air proportioning shutters with a butterfly gas valve and/or a Sensitrol Oil Valve. Fuel oil enters the Sensitrol Oil Valve via a swivel type joint mounted on the hinge.

Basic Gas Burner consists of the above three sections fitted with a manually positioned and lockable firing rate control lever (shown in burner photo) and a butterfly gas valve with linkage assembly. Refer to Bulletin 6140 for main and pilot gas accessories.

Basic Light Oil Burner consists of the three basic sections described above, with the following equipment: a manually positioned and lockable firing rate control lever, a Sensitrol Oil Valve with linkage assembly, and a flange mounted oil atomizer assembly. Refer to Table 2 for oil and atomizing medium pressure/flow requirements. Specify this burner arrangement for oils up to and including #4 grade.

Basic Heavy Oil Burner is similar to the light oil burner except atomizer, Sensitrol Oil Valve, and oil piping are sized and arranged to accommodate heavy oil or crude oil. Oil temperature is maintained electrically within the burner through four low wattage cartridge heaters: one within Sensitrol valve body, two in heater blocks attached to oil tube, and one in a heater block attached to the nozzle. The hinge assembly is fitted with a hot oil return valve (shown in the photograph). This burner is recommended for all heavy oils, including blended grades.

Basic Dual-Fuel Burner is similar to oil burner except provision is made for burning either gas or a pre-selected grade of oil. A dual-fuel burner fitted for heavy oil permits use of any grade, ranging from diesel through very heavy #6.

Flame Supervision and Control. There is a long list of optional accessories that can be added to the basic burners described above. In many applications of this burner, the combustion chamber is below 1400 F. Electronic flame supervisory systems are strongly recommended. Such systems are offered by North American and others. A specially designed system is available for boilers.

Your local Fives North American sales engineer can help select burner accessories required to make a firing system that will be reliable, efficient, and safe to operate.

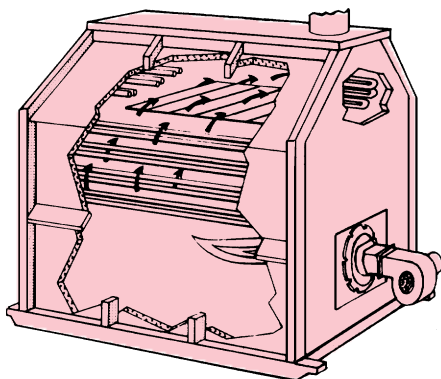

Cooking Oil Heater

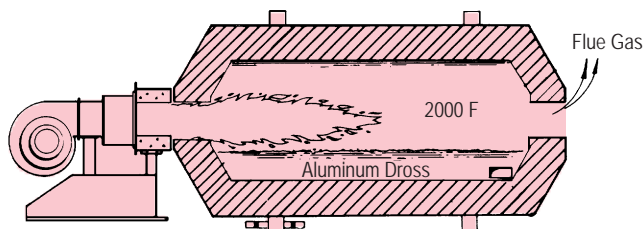

Aluminum Dross Reclaiming Furnace

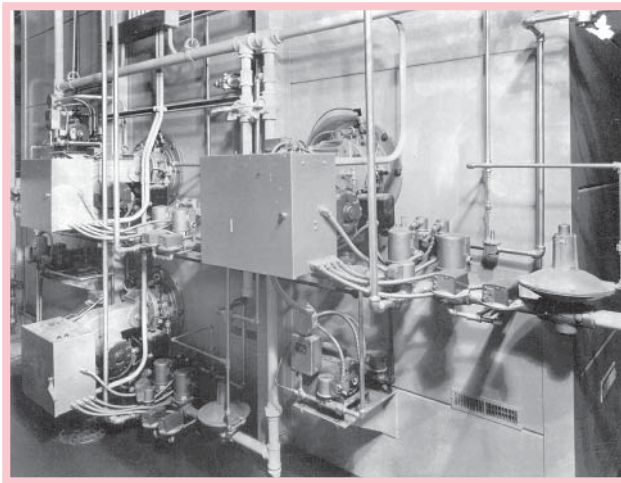

Pathological Incinerator



Liquid Asphalt Heaters

Table 2.

Burner Size Designation ^①	Flows and Pressures Req'd at Burners Size ^⑤	Atomizing Mediums ^②		Oil Pressures ^③		Minimum Gas Pressures ^④ "wc	Gas Metering Valve
		Comp. air flow, scfm	Steam flow, lb/hr	Light oil, psig	Heavy oil, psig		
A		4	30	120	70	2.2	3"
B		4	50	90	65	3.1	3"
CL (heavy oil)		8	70	-	80	2.8	4"
C (light oil)		4	91	85	-	2.2	4"
C (heavy oil)		7	130	-	70	2.2	4"
CS (light oil)		16	110	125	-	14.0	4"
D		16	130	50	60	4.0	6"
E (light oil)		14	182	55	-	3.0	8"
E (heavy oil)		28	168	-	70	3.0	8"
FA		28	200	75	90	6.0	8"

① Letters designate frame size—see Table 1, page 2.

② Oil and dual-fuel burners require an accessory package for the atomizing medium. Pressures required at the inlet of that package are 75-100 psi for air and 50-125 psi for steam.

③ Oil and dual-fuel burners require oil delivered to burner hinge at a viscosity below 100 SSU and at pressures listed above. If a liquid fuel other than commercial fuel oil is to be used, consult North American for recommendations of pressure and flow requirements.

④ Gas burners are intended for use with natural gas or propane. Listed pressures are for natural gas—consult Fives North American for propane pressures. Pressures listed are for system sizing only. **They are not for ratio adjustment.**

⑤ Gas piping upstream of burner gas metering butterfly valve to be same size as the metering valve for a minimum of 10 pipe diameters. Place reducer, if used, as close as possible to the gas regulator.

WARNING: Situations dangerous to personnel and property may exist with the operation and maintenance of any combustion equipment. The presence of fuels, oxidants, hot and cold combustion products, hot surfaces, electrical power in control and ignition circuits, etc., are inherent with any combustion application. Parts of this product may exceed 160F in operation and present a contact hazard. Fives North American Combustion, Inc. urges compliance with National Safety Standards and insurance Underwriters recommendations, and care in operation.