

8775 Quick Disconnects for Oil, Compressed Air, and Natural Gas

- The 8775 couplings allow you to couple and uncouple your hoses quickly.
- Traditional ball-locking two-piece construction that allows end fitting versatility.
- Low pressure drop across couplings.
- Double automatic bleed-off valve built into both couplings that will enable you to connect against trapped static pressures.
- All steel couplings are zinc yellow dichromate plated with viton gaskets.
- Temperature rating (-20° to 375°) F



Part Number	Size*	Max Working Pressure (PSIG)	CV Factor
8775-02	3/8"	4500	.98
8775-01	1/2"	4000	2.5
8775-0	3/4"	3500	4.6
8775-1	1"	2000	7.2

*larger sizes available up to 4" **without built in bleed off valve.**
Please consult Fives North American for pricing and information.

8778A Pipe Couplings for High or Low Pressure Air or Natural Gas

- The 8778A pipe couplings are designed to simplify installation and ensure a tight seal with a push on gasket.
- They can be used to connect steel piping with diameters (1/2" through 4").
- Resistant to natural gas, natural gas odorants, carbon dioxide, water, and UV light.
- The coupling sleeve material is steel with an epoxy coating.
- Gasket material is buna nitrile.
- Temperature rating (-20° to 170°) F.



Part Number	Size	Followers (Epoxy Coated)	Nuts & Bolts	Max Working Pressure (PSIG)
8778A-01	1/2"	Ductile Iron	1/2"	150
877A-0	3/4"	Ductile Iron	1/2"	150
8778A-1	1"	Ductile Iron	1/2"	150
8778A-2	1 1/4"	Ductile Iron	1/2"	150
8778A-3	1 1/2"	Ductile Iron	1/2"	150
8778A-4	2"	Steel	5/8"	400
8778A-5	2 1/2"	Steel	5/8"	400
8778A-6	3"	Steel	5/8"	400
8778A-7	4"	Steel	5/8"	400

DIMENSIONS SHOWN ARE SUBJECT TO CHANGE. PLEASE OBTAIN CERTIFIED PRINTS FROM FIVES NORTH AMERICAN COMBUSTION, INC.
IF SPACE LIMITATIONS OR OTHER CONSIDERATIONS MAKE EXACT DIMENSION(S) CRITICAL.

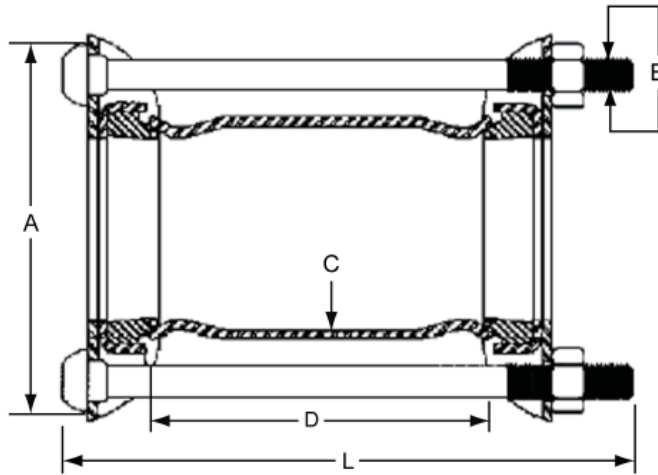

Part Number	Pipe		Follower "A"	Sleeve			Bolts			Weight (Lbs.)
	Size	O.D.		"C"	"D"	"B"	"L"	No.		
8778A-01	1/2"	0.840	3 3/8	0.120	7.0	0.5	9.0	2	3.00	
8778A-0	3/4"	1.050	3 15/16	0.120	7.0	0.5	9.0	2	3.00	
8778A-1	1"	1.315	4 1/2	0.120	7.0	0.5	9.0	2	4.00	
8778A-2	1 1/4"	1.660	4 5/8	0.120	7.0	0.5	9.0	2	5.00	
8778A-3	1 1/2"	1.900	4 7/8	0.120	7.0	0.5	9.0	2	5.50	
8778A-4	2"	2.375	6 3/4	0.156	7.0	0.6	11.0	3	8.00	
8778A-6	3"	3.500	7 1/2	0.156	7.0	0.6	11.0	3	15.00	
8778A-7	4"	4.500	8 1/2	0.188	7.0	0.6	11.0	3	17.00	

8778A Installation Instructions

1. Pipe must be secured to prevent pipe pullout or movement.
2. Both pipe surfaces must be free and clean of any contaminants at a minimum distance equal to the overall length of the coupling. Pipe wrapping or coating pipe should be cut back a distance equal to the overall length of the coupling.
3. Pipe must be free of longitudinal gouges.
4. Apply soap to all gaskets and pipe to ensure proper lubrication during installation.
5. Insert the coupling between the two pieces of pipe and insure the coupling is centered.
6. Torque the nuts on the coupling assembly evenly to the following values:
 - 1/2" nuts- 30 Ft.lbs. MIN
 - 5/8" nuts- 80 Ft.lbs. MIN
7. Leak test prior to use.

DIMENSIONS SHOWN ARE SUBJECT TO CHANGE. PLEASE OBTAIN CERTIFIED PRINTS FROM FIVES NORTH AMERICAN COMBUSTION, INC.
IF SPACE LIMITATIONS OR OTHER CONSIDERATIONS MAKE EXACT DIMENSION(S) CRITICAL.

Quick Disconnect Cam and Groove Couplings For Liquid Use Only

- **NOTE: CAM AND GROOVE COUPLINGS ARE NOT DESIGNED FOR COMPRESSED GAS APPLICATIONS**
- Allows for quick disconnect of your pipe without the use of tools
- Coupling is constructed from forged brass
- Gasket material is Viton®
- Temperature rating (-20° to 350°) F

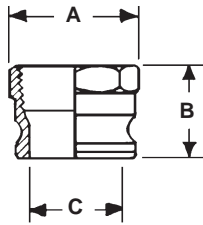

ADAPTER Part A

Part number	Pipe size	Adapters Part "A"			Max working pressure (PSIG)
		A	B	C	
R210-3000	1/2	1	1 9/16	9/16	350
R210-3001	3/4	1 3/8	1 17/32	3/4	350
R210-3002	1	1 15/16	2 1/8	1 1/8	350
R210-3003	1 1/4	2 15/16	2 1/8	1 1/8	350
R210-3004	1 1/2	2 9/32	2 3/16	1 3/8	350
R210-3005	2	2 11/16	2 7/16	1 25/32	350
R210-3006	2 1/2	3 5/16	2 11/16	2 5/32	250
R210-3007	3	3 15/16	2 3/4	2 7/8	250
R210-3008	4	5	3 1/16	3 7/8	100

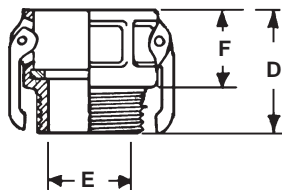

COUPLER Part B

Part number	Pipe size	Couplers Part "B"			Max working pressure (PSIG)
		D	E	F	
R210-3020	1/2	1 15/16	9/16	1 15/16	350
R210-3021	3/4	2 1/16	3/4	1 3/8	350
R210-3022	1	2 7/16	1	1 9/16	350
R210-3023	1 1/4	2 3/16	1 1/4	2 3/16	350
R210-3024	1 1/2	2 3/4	1 3/8	1 7/8	350
R210-3025	2	3 1/8	2	1 3/16	350
R210-3026	2 1/2	3 1/2	2 3/8	2 1/4	250
R210-3027	3	3 9/16	2 7/8	2 3/8	250
R210-3028	4	4	3 15/16	2 7/16	100

DIMENSIONS SHOWN ARE SUBJECT TO CHANGE. PLEASE OBTAIN CERTIFIED PRINTS FROM FIVES NORTH AMERICAN COMBUSTION, INC.
IF SPACE LIMITATIONS OR OTHER CONSIDERATIONS MAKE EXACT DIMENSION(S) CRITICAL.

8779 Pipe Connectors for low pressure air

These compression pipe couplings offer a simple, fast means of connecting two air pipes of the same size. They provide all the convenience of a flange or union without the necessity of cutting pipe threads and without carefully cut pipe lengths.

These connectors can be easily installed on plain end, threaded, or grooved pipe (or a combination of these) to provide a permanent joint. The band type construction holds the entire surface of the joint in uniform compression. The connector consists of a heavy gauge zinc-coated outer shell; a rust resistant steel inner sleeve with precision die-cut teeth (that forms a tight, complete seal when the outer shell is tightened); and a precision die-cut black neoprene gasket-liner.

Maximum temperature: 250 F

Maximum pressure: 15 psi

Connector designation	Dimensions in inches			Approximate weight, lb
	A	B	C	
8779-4	2	4	4 ³ / ₁₆	3
8779-5	2½	4	4 ¹ / ₁₆	3½
8779-6	3	4	5 ¹³ / ₃₂	3½
8779-7	4	4	6 ¹³ / ₃₂	4½
8779-8	6	6	8 ⁹ / ₁₆	8½
8779-9	8	8	11½	13½

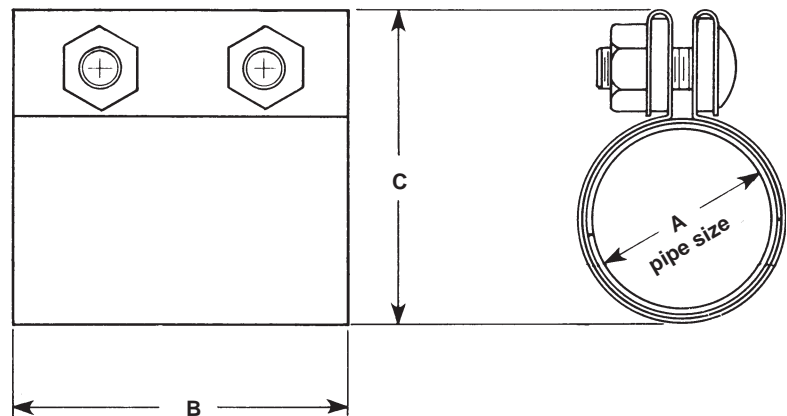
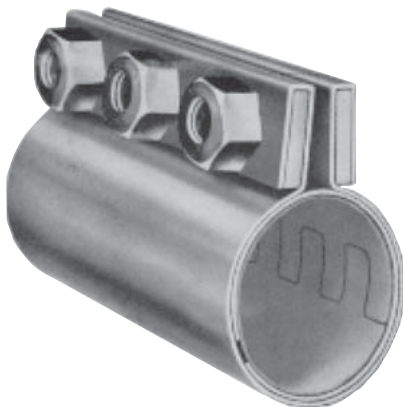

Pipe connector for convenient joining of low pressure air pipes.

DIMENSIONS SHOWN ARE SUBJECT TO CHANGE. PLEASE OBTAIN CERTIFIED PRINTS FROM FIVES NORTH AMERICAN COMBUSTION, INC. IF SPACE LIMITATIONS OR OTHER CONSIDERATIONS MAKE EXACT DIMENSION(S) CRITICAL.

WARNING: Situations dangerous to personnel and property may exist with the operation and maintenance of any combustion equipment. The presence of fuels, oxidants, hot and cold combustion products, hot surfaces, electrical power in control and ignition circuits, etc., are inherent with any combustion application. Parts of this product may exceed 160F in operation and present a contact hazard. Fives North American Combustion, Inc. urges compliance with National Safety Standards and insurance Underwriters recommendations, and care in operation.