

- **Saves up to 40% fuel over cold air fired burners**
- **Unique high efficiency swirl vane design provides superior thermal performance**
- **Available for a wide range of radiant tube sizes from 4" to 8"**
- **Air and flue connections rotate independently in 45° increments for easy connection**
- **Rugged cast alloy construction**

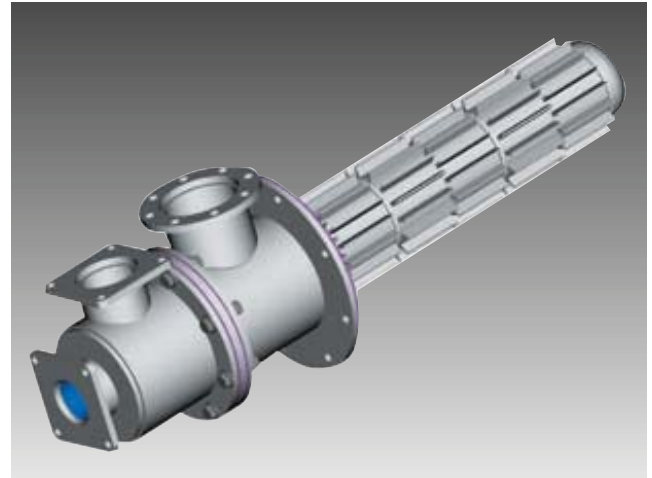

Features:

The 8480 Plug-In Recuperator is designed as a companion to the Evenglow family of radiant tube burner products. Combined with the 4723 Evenglow burner, the Plug-In recuperator offers exceptional performance in both uniform radiant tube temperature and thermal efficiency.

The 8480 Plug-In Recuperator features thermally optimized vanes to provide the highest thermal efficiency while minimizing pressure drop. The outer vanes are staggered and segmented to trip the thermal boundary layer and increase heat transfer. Inside, swirling vanes increase the turbulence, increasing heat transfer. Together, these surfaces are the core for the exceptional performance of the 8480.

The construction features durable cast alloy heat exchanger sections resulting in long recuperator life. These sections allow for optimization of the length of the heat exchanger to fit the performance needs of application. The independent exhaust and air inlet bodies can be rotated independently in 45° increments. Four sizes of the 8480 recuperator assure a "proper fit" to a wide range of radiant tube diameters from 4" ID through 8" ID. An optional crossover kit is available to connect the combustion air from the recuperator to the burner.

Table 1 illustrates the design capacities and radiant tube size combinations for the recuperator. Maximum exhaust gas temperature into the recuperator is 2100 F.

Consult your local Fives North American Application Specialist for a customized solution for your application today.

Table 1. Design Specifications

Recuperator designation	Radiant Tube Inside Diameter (inches)	Recuperator Capacity* (scfh combustion air)	Air Side Recuperator Pressure Drop† ("wc)	Flue Side Recuperator Pressure Drop‡ ("wc)
8480-400/4—	4.1 - 5.0	2400	6.0	4.2
8480-500/3—	5.1 - 6.0	3600	6.0	3.3
8480-600/3—	6.1 - 7.0	6200	6.0	3.4
8480-700/3—	7.1 - 8.0	9600	6.0	3.6

* Higher capacities can be achieved at higher pressure drops.
 † At maximum air preheat temperatures.
 ‡ With smallest radiant tube size.

DIMENSIONS

inches

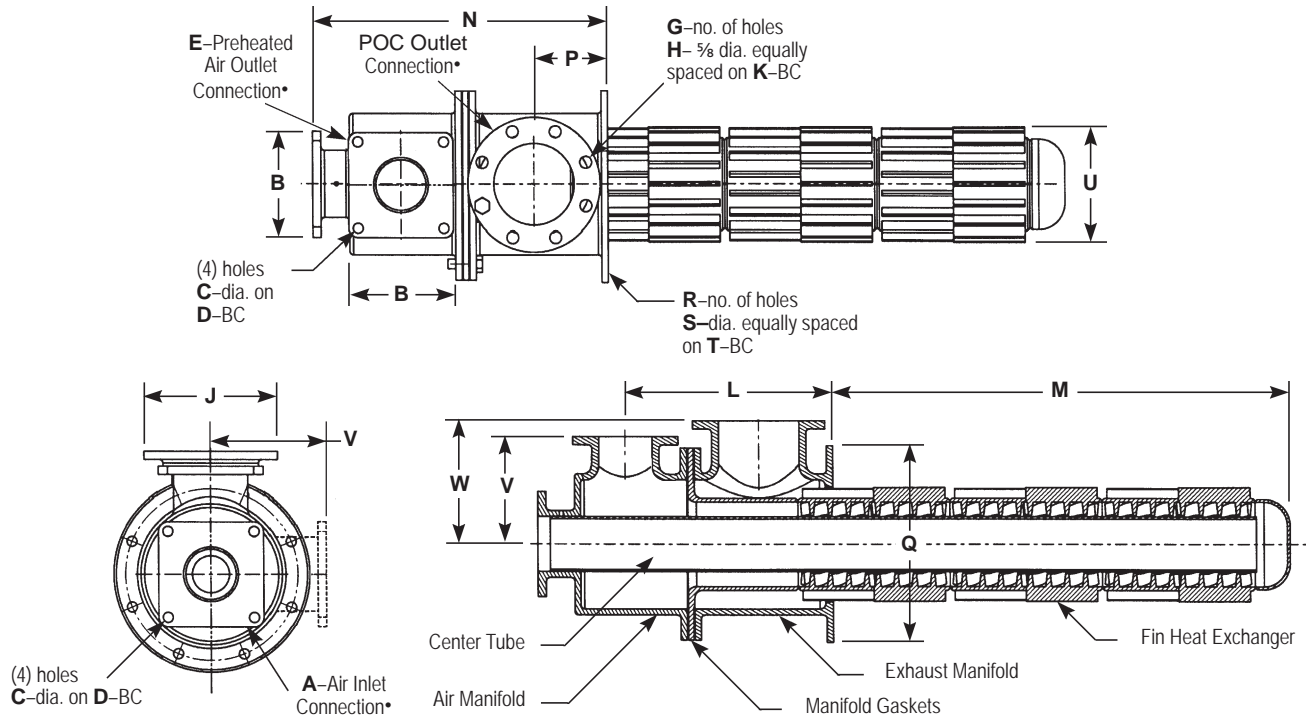

• Refers to Companion Flange pipe size.

Recuperator designation	A	B	C	D	E	F	G	H	J	K	L	M	N	P	Q	R	S	T	U	V	W	Wt, lb
8480-400/4	2	4 ¹ / ₁₆	0.348	4 ⁹ / ₁₆	2 ¹ / ₂	3	4	1 ⁷ / ₃₂	6	4 ³ / ₄	11 ¹ / ₁₆	24	14 ⁵ / ₈	3 ²⁵ / ₃₂	9	8	3/4	7 ¹ / ₂	3 ¹⁵ / ₁₆	4 ¹¹ / ₁₆	5 ³ / ₁₆	71
8480-500/3	2 ¹ / ₂	4 ¹ / ₁₆	0.348	4 ⁹ / ₁₆	2 ¹ / ₂	3	4	1 ⁷ / ₃₂	6	4 ³ / ₄	11 ¹ / ₁₆	24	14 ⁵ / ₈	3 ²⁵ / ₃₂	9	8	3/4	7 ¹ / ₂	4 ¹⁵ / ₁₆	4 ¹¹ / ₁₆	5 ³ / ₁₆	88
8480-600/3	3	5 ⁹ / ₁₆	1 ³ / ₃₂	6 ³ / ₈	3	4	8	5/8	7	5 ¹⁵ / ₁₆	12 ¹³ / ₁₆	24	16 ¹³ / ₁₆	4 ¹³ / ₃₂	11	8	7/8	9 ¹ / ₂	5 ¹⁵ / ₁₆	5 ¹¹ / ₁₆	6 ¹¹ / ₁₆	125
8480-700/3	4	5 ⁹ / ₁₆	1 ³ / ₃₂	6 ³ / ₈	4	6	8	5/8	9	7 ⁷ / ₈	15 ⁹ / ₁₆	24	20	5 ¹³ / ₃₂	13 ¹ / ₂	8	7/8	11 ³ / ₄	6 ¹⁵ / ₁₆	6 ³ / ₁₆	7 ³ / ₁₆	150

DIMENSIONS SHOWN ARE SUBJECT TO CHANGE. PLEASE OBTAIN CERTIFIED PRINTS FROM FIVES NORTH AMERICAN COMBUSTION, INC.
IF SPACE LIMITATIONS OR OTHER CONSIDERATIONS MAKE EXACT DIMENSION(S) CRITICAL.

8480 COMPANION FLANGES AND GASKETS						
Flanges			Gaskets			
Recuperator	Air Inlet	Air Outlet	POC Outlet	Air	Mounting	POC
8480-400	4-1695-2	4-1695-3	8767D-6	4-47579-2	4-32750-1	OA3-2302-22H4
8480-500	4-1695-3	4-1695-3	8767D-6	4-47579-2	4-32750-2	OA3-2302-22H4
8480-600	4-1694-4	4-1695-4	8767D-7	4-47579-3	4-32750-3	OA3-2302-23H4
8480-700	4-1695-5	4-1695-5	8767D-8	4-47579-3	4-32750-4	OA3-2302-24H4

Not included with Recuperator. Must order separately.

ORDERING INFORMATION

8480 -

--	--	--

 /

--	--

Tube ID (inches)

400	4.1 - 5.0
500	5.1 - 6.0
600	6.1 - 7.0
700	7.1 - 8.0

Number of Heat Exchange Sections

3	-500, -600, and -700
4	-400 only

Preheated Air Outlet Location

- | |
|---|
| A |
| B |
| C |
| D |
| E |
| F |
| G |
| H |

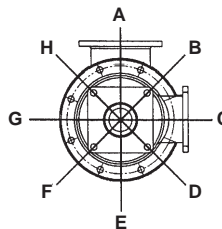

Example: To order a three-section recuperator for a 6½" ID tube with the preheated air outlet orientation shown the part number would be 8480-600/3D.

Specify preheated air outlet location relative to flue gas connection location at "A" position. See example.

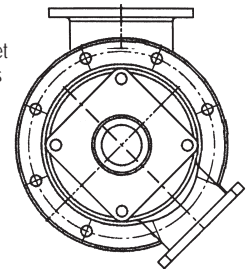

WARNING: Situations dangerous to personnel and property may exist with the operation and maintenance of any combustion equipment. The presence of fuels, oxidants, hot and cold combustion products, hot surfaces, electrical power in control and ignition circuits, etc., are inherent with any combustion application. Parts of this product may exceed 160F in operation and present a contact hazard. Fives North American Combustion, Inc. urges compliance with National Safety Standards and insurance Underwriters recommendations, and care in operation.